

TLS130B Series

Oriel® Tunable Light Source System



Tunable Light Sources
TLS130B-300X TLS130B-250Q

User's Manual

Oriel®
INSTRUMENTS
A Newport Corporation Brand

TABLE OF CONTENTS

GENERAL INFORMATION	5
SYMBOLS AND DEFINITIONS.....	5
GENERAL WARNINGS.....	6
ELECTRICAL HAZARDS.....	6
FIRE HAZARDS.....	7
LAMP HANDLING	7
INTRODUCTION	8
SYSTEM SETUP.....	10
ITEMS INCLUDED WITH SYSTEM.....	10
UNPACKING	10
CHOOSING A LOCATION	11
USING THE TLS FOR THE FIRST TIME.....	11
LAMP INSTALLATION.....	13
LAMP HANDLING PRECAUTIONS.....	13
ACCESSING THE LAMP COMPARTMENT.....	13
XENON LAMP INSTALLATION	16
QTH LAMP INSTALLATION.....	21
ELECTRICAL AND COMPUTER CONNECTIONS	22
LAMP STARTUP.....	25
SOFTWARE CONFIGURATION	28
ESTABLISHING MONOCHROMATOR COMMUNICATION	30
SHUTTER CONTROL.....	31
SELECTING WAVELENGTH UNITS	31
SETTING MONOCHROMATOR WAVELENGTH OUTPUT.....	32
MONOCHROMATOR OFFSET	32
MONOCHROMATOR CALIBRATION PARAMETERS.....	32
GRATING SELECTION PARAMETERS.....	33
FILTER SELECTION PARAMETERS	34
SLIT ADJUSTMENTS.....	35
LAMP ALIGNMENT.....	38
QTH LAMP ALIGNMENT.....	42
XENON ARC LAMP ALIGNMENT.....	46
MONOCHROMATOR RESOLUTION.....	49
OUTPUT OPTICS.....	50
MANUAL IRIS.....	50
OUTPUT FLANGE.....	50
COUPLING ADDITIONAL OPTICS OR A FIBER TO THE TLS	51
MOUNTING A LENS/FILTER	51
COUPLING A FIBER.....	53
MAINTENANCE	55
LAMP REPLACEMENT.....	55
CLEANING.....	55
ARC LAMP HOUSING INSPECTION	55
QTH LAMP HOUSING INSPECTION	57
TROUBLESHOOTING.....	58
POWER SUPPLY ERROR MESSAGES	58
DIFFICULTY IGNITING ARC LAMP	59

LAMP CARE AND HANDLING	59
LAMP HOUSING THERMOSTAT.....	59
SPECIFICATIONS	61
TLS SYSTEM	61
SOFTWARE FUNCTION AND REQUIREMENTS.....	62
OPTICAL ACCESSORIES AND RELATED PRODUCTS	63
APPENDIX A: OPTIONAL HAND CONTROLLER.....	63
CE DECLARATION.....	63
WARRANTY AND SERVICE	64
CONTACTING ORIEL INSTRUMENTS.....	64
REQUEST FOR ASSISTANCE / SERVICE	65
REPAIR SERVICE.....	65
NON-WARRANTY REPAIR.....	65
WARRANTY REPAIR	66
LOANER / DEMO MATERIAL.....	67

LIST OF FIGURES

Figure 1: Exploded view diagram.....	9
Figure 2: Basic System Block Diagram and Dimensions in Inches (mm).....	9
Figure 3: TLS Setup Process for Optimum System Performance.....	11
Figure 4: The On/Off switch of the Cornerstone 130B Monochromator circled in red.....	12
Figure 5: Lamp Housing Adjustment Controls.....	14
Figure 6: Opening Lamp Housing Door.....	15
Figure 7: Preparation for arc lamp installation.....	16
Figure 8: Socket Adapter Installation.....	17
Figure 9: Lamp Prepared for Installation.....	18
Figure 10: Arc Lamp Orientation.....	18
Figure 11: Attaching Sensor Block.....	19
Figure 12: Interlock Open Error Message of the OPS Series Power Supply	20
Figure 13: Tightening Thumbscrew.....	20
Figure 14: Xenon Arc Lamp Installed.....	21
Figure 15: QTH Lamp Installation.....	21
Figure 16: USB 2.0 or RS-232 Cable Connection to the Monochromator	23
Figure 17: Lamp Housing Connection	24
Figure 18: Power Supply Connections.....	24
Figure 19: OPS Series Power Supply Front Panel.....	25
Figure 20: The LCD display of OPS power supply.....	26
Figure 21: Instrument Status Indicators	29
Figure 22: RS232 Communication Setup.....	30
Figure 23: Monochromator Configuration Menu	30
Figure 24: Shutter Control	31
Figure 25: Selecting Wavelength Units.....	31
Figure 26: Selecting a Monochromator Output Wavelength	32
Figure 27: Monochromator Wavelength Offset.....	32
Figure 28: Monochromator Calibration Parameters.....	33
Figure 29: Grating Selection Table.....	33
Figure 30: Filter Selection Table.....	34
Figure 31: The fixed slit holder at the input port of the monochromator.....	35
Figure 32: The fixed slit holder at the output port of the monochromator.....	36

Figure 33: A 280 μm fixed slit with the notch oriented upward properly for installation.....	36
Figure 34: The output of the TLS set to 550 nm, but no fixed slits installed.	37
Figure 35: Lamp horizontal and vertical position adjustment knobs at the lamp housing door.....	39
Figure 36: Rear reflector adjustment knobs on the side of the lamp housing.....	40
Figure 37: Condenser lens assembly adjustment knob and adjustment lever at output of lamp housing..	40
Figure 38: The light path and the optics of the TLS starting from the lamp to the filter wheel.	41
Figure 39: The yellow image at the right represents the secondary image of the QTH/Arc Lamp from the rear reflector of the lamp housing. To move this secondary image in the desired direction, rotate each Rear Reflector Adjustment knob as indicated in the image on the right.	42
Figure 40: Primary image of QTH lamp filament after adjusting condenser lens assembly.	43
Figure 41: QTH lamp primary image (red box) and secondary reflected image (green box).....	44
Figure 42: QTH lamp reflected secondary image superimposed onto primary image.	45
Figure 43: The light output of a properly aligned QTH lamp.	45
Figure 44: Xe arc lamp primary image (red) and secondary reflected image (blue).	47
Figure 45: Xe arc lamp output with primary arc image centered.	47
Figure 46: Primary (red) and secondary (blue) Xe arc lamp images superimposed for alignment.	48
Figure 47: Uniform output of a properly aligned Xe lamp.	48
Figure 48: Manual iris added to the output optics of the TLS.	50
Figure 49: The 1.5 inch flange adapter of the TLS can be removed to reduce the output flange to 1.0 inch, increasing the mechanical compatibility of the TLS.....	51
Figure 50: The 77330 Focusing Lens Assembly coupled to the TLS. The bottom view shows the 77792 male-male flange for mechanical coupling.....	52
Figure 51: Fiber bundle coupled to the output of the TLS with a fiber bundle focusing assembly.....	54
Figure 52: The spot size output of the TLS with the use of a fiber light guide.	54
Figure 53: Arc Lamp Housing Construction.....	56
Figure 54: Normal vs. Damaged Arc Lamp.....	60
Figure 55: 74009 Monochromator Hand Controller.....	63



GENERAL INFORMATION

Thank you for your purchase of this Tunable Light Source system from Oriel Instruments.

Please carefully read the following important safety precautions prior to unpacking and operating this equipment. In addition, please refer to the complete User's Manual for additional important notes and cautionary statements regarding the use and operation of the system.

Do not attempt to operate the system without reading all the information provided with each of the components.

SYMBOLS AND DEFINITIONS

	WARNING Situation has the potential to cause damage to property or equipment as well as bodily harm or death.
	ELECTRICAL SHOCK Hazard arising from dangerous voltage. Any mishandling could result in irreparable damage to the equipment, and personal injury or death.
	EUROPEAN UNION CE MARK The presence of the CE Mark on Newport Corporation equipment means that it has been designed, tested and certified as complying with all applicable European Union (CE) regulations and recommendations.
Note:	Additional important information the user or operator should consider.

Please read all instructions that were provided prior to operation of the system.

If there are any questions, please contact Oriel Instruments or the representative through whom the system was purchased.

GENERAL WARNINGS

- Read all warnings and operating instructions for this system prior to setup and use.
- Do not use this equipment in or near water.
- To prevent damage to the equipment, read the instructions in the equipment manual for proper input voltage.
- This equipment is grounded through the grounding conductor of the power cords.
- Route power cords and other cables so they are not likely to be damaged.
- Disconnect power before cleaning the equipment
- Do not use liquid or aerosol cleaners; use only a damp lint-free cloth.
- Disconnect all electrical power sources before servicing the equipment.
- To avoid explosion, do not operate this equipment in an explosive atmosphere.
- Qualified service personnel should perform safety checks after any service.
- If this equipment is used in a manner not specified in this manual, the protection provided by this equipment may be impaired.
- To prevent damage to equipment when replacing fuses, locate and correct the problem that caused the fuse to blow before re-applying power.
- Do not block ventilation openings.
- Do not position this product in such a manner that would make it difficult to disconnect the power cords.
- Use only the specified replacement parts.
- Follow precautions for static sensitive devices when handling this equipment.
- This product should only be powered as described in the manual.
- Do not remove the cover for normal usage

ELECTRICAL HAZARDS

Make all connections to or from the power supply with the power off.

Do not use the power supply without its cover in place. Lethal voltages are present inside.

FIRE HAZARDS

Lamps are extremely hot during operation, and for several minutes after being shut off. Keep flammable objects away from the lamp and lamp housing.

To avoid fire hazard, use only the specified fuses with the correct type number, voltage and current ratings as referenced in the appropriate locations in the service instructions or on the equipment. Only qualified service personnel should replace fuses.

LAMP HANDLING

Read all information and warnings provided with lamp.

Xenon arc lamps used in this system is filled with rare gas at high pressure, so there is a danger of lamp explosion due to mechanical failure. This is particularly true when the lamp is operating since the internal pressure can reach tens of atmospheres. Thermal strains can cause the lamp to explode under certain conditions.

Never touch any lamp with bare fingers or other contaminates. Skin oil or other substances can burn into the lamp envelope during operation and negatively affect the lamp's performance and lifetime.

Always wear appropriate gloves and impact-resistant goggles when handling any lamp. Avoid any mechanical strain during handling. Do not operate the lamp without all housing panels in place.

Lamps become very hot after only a few minutes of operation (up to 150°C) and remain quite hot for at least 10 to 15 minutes after being turned off.

INTRODUCTION

Oriel Instruments has upgraded their Tunable Light Source (TLS) product line. These fully integrated, pre-aligned, factory-characterized illumination systems have the following additional benefits:

- Integrated the redesigned Cornerstone 130B 1/8 m Monochromator for faster scan speeds.
- Both USB 2.0 and RS232 control options included on all models of the Cornerstone™ 130B 1/8 m Monochromator.
- OPS Series Power Supply for compact design improvement and increased light output stability.
- Fixed slit wheels on the monochromator have been replaced with interchangeable fixed slits which provide better accuracy and repeatability.
- Manual iris added to light output path.
- 1-inch output flange for additional compatibility with other Newport products.
- Upgraded TracQ Basic Data Acquisition & Spectroscopy Software, Version 6.7.

The TLS is capable of outputting broadband or monochromatic light from 300-1800 nm (Xe arc lamp version) or 350-1800 nm (QTH lamp version) with resolution as great as 0.7 nm (slit size dependent). All components are firmly secured to the mounting board and the TLS is ready to use once the lamp is installed and all necessary cables have been connected. The new mounting board design has handles mounted for easy transporting of the unit. Mounting feet at the bottom of the mounting board help with placing and leveling the system.

The motorized filter wheel preceding the monochromator includes filters to eliminate second order effects that would otherwise occur within the monochromator. Fixed slit holders are located at the input and output ports of the monochromator, allowing the user to select the output beam size and adjust the monochromatic light output to a resolution as great as to 0.7 nm, simply by interchanging fixed slits. The 1.5-inch flange adapter coupled to the end of the TLS can be easily removed to make the TLS compatible with Newport's line of 1.0-inch flanged products such as focusing optics, calibrated detectors, and other optical accessories.

Two models of the TLS130B series are available, differentiated by lamp type:

- TLS130B-300X: 300 W Xenon lamp
- TLS130B-250Q: 250 W QTH lamp

The TLS models also come with the latest, most improved version of TracQ Basic, Oriel's instrument control and data acquisition software. Working with the Cornerstone 130B 1/8 m Monochromator's USB or RS232 port, TRACQ-BASIC switches the filter wheel position to the correct order sorting filter and the monochromator to the proper grating and grating position based on the TLS wavelength output chosen by the operator.

When used with compatible detection systems such as Oriel's LIDA-SRS-KIT or various Newport power meters, TracQ is a complete radiometry system control software, capable of displaying real time data acquisition. No prior knowledge of software programming is necessary to install or operate TracQ.

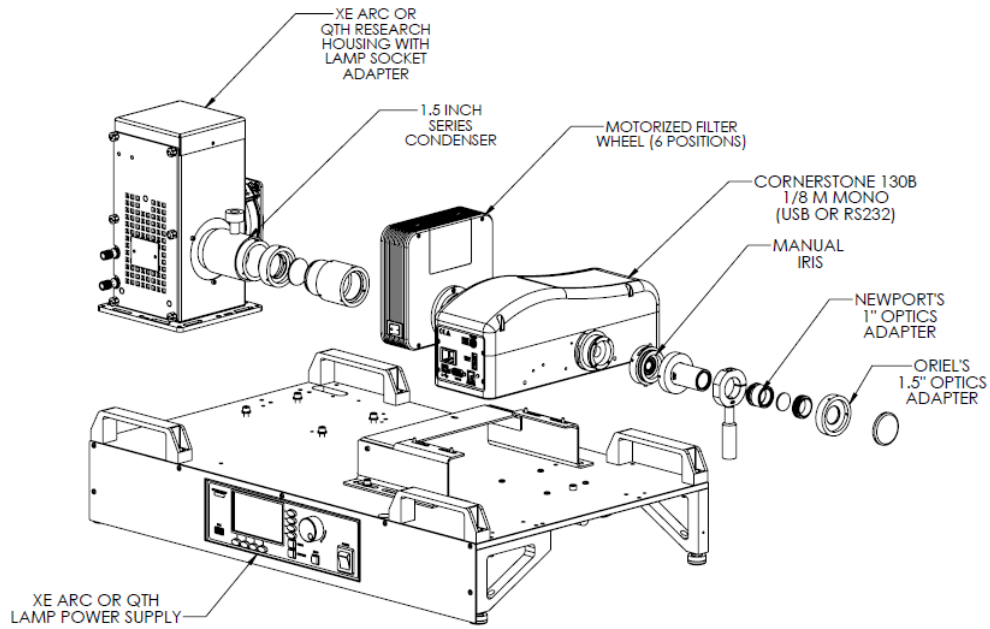

Figure 1: Exploded view diagram

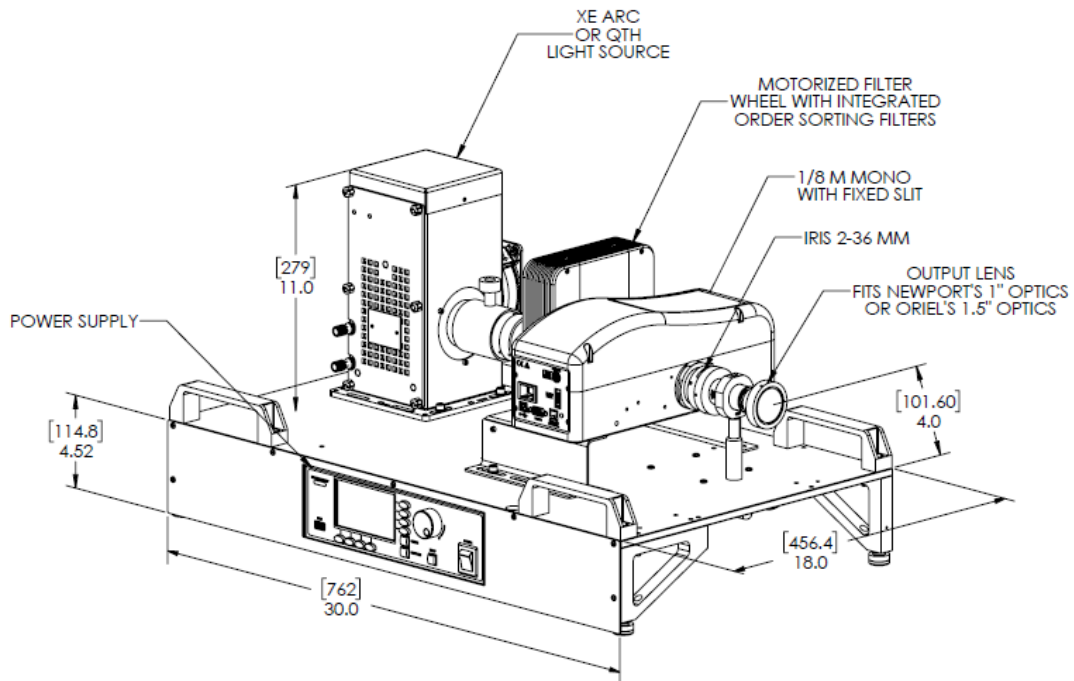

Figure 2: Basic System Block Diagram and Dimensions in Inches [mm]

SYSTEM SETUP

ITEMS INCLUDED WITH SYSTEM

Oriel Instruments provides a pre-aligned Tunable Light Source with all components firmly secured to a customized mounting plate. The system includes:

- Power Supply, Research Lamp Housing, Filter Wheel, Cornerstone 130B Monochromator, and Coupling Optics mounted to a custom baseplate
- QTH (TLS130B-250Q) / Xe (TLS130B-300X) Lamp (Xe lamps have brass socket adapter attached)
- Two pcs 77217 (280 μm) fixed slit
- Two pcs 77216 (600 μm) fixed slit
- Lamp housing connection cable
- AC power cable for lamp power supply
- AC Power cable for monochromator
- USB and RS232 cable
- USB thumb drive with the latest version of TracQ BASIC Control and Data Acquisition software, the latest version of Mono Utility, user manuals, and factory characterization data for each system
- Filter wrench, 3/16" Allen wrench
- Oriel flange converter to Newport 1" Lens Tube

UNPACKING

Remove all items from the shipping containers and verify each item is accounted for. The system is carefully packaged to minimize the possibility of damage during shipment. Inspect the shipping boxes for external signs of damage or mishandling. Inspect the contents for damage.

If any item is missing or damaged, immediately contact Oriel Instruments or the Newport representative from whom the system was purchased.

It is suggested to save the packaging material and shipping container, in case the equipment needs to be relocated at a future date.



WARNING

Do not attempt to operate this equipment if there is evidence of shipping damage or there is suspicion that the equipment will not operate correctly. Damaged equipment may present hazards.

CHOOSING A LOCATION

Choose an installation location where the power requirements can be met for the system. Be sure power is not applied to the system until the setup has been completed.

The environment should be that of a typical laboratory atmosphere, without excessive humidity and contaminants in the air. Do not allow the ventilation holes on the system's components or its computer to be blocked. Air should be able to circulate freely around the system.

When the system is placed in its final location, check to ensure that none of the pre-assembled items have become loose during handling.

USING THE TLS FOR THE FIRST TIME

The TLS is a plug and play system designed for minimum setup required on the user's end to make the unit operational for use. After unpacking the TLS, follow the steps in the flow chart below, starting with Lamp Installation.

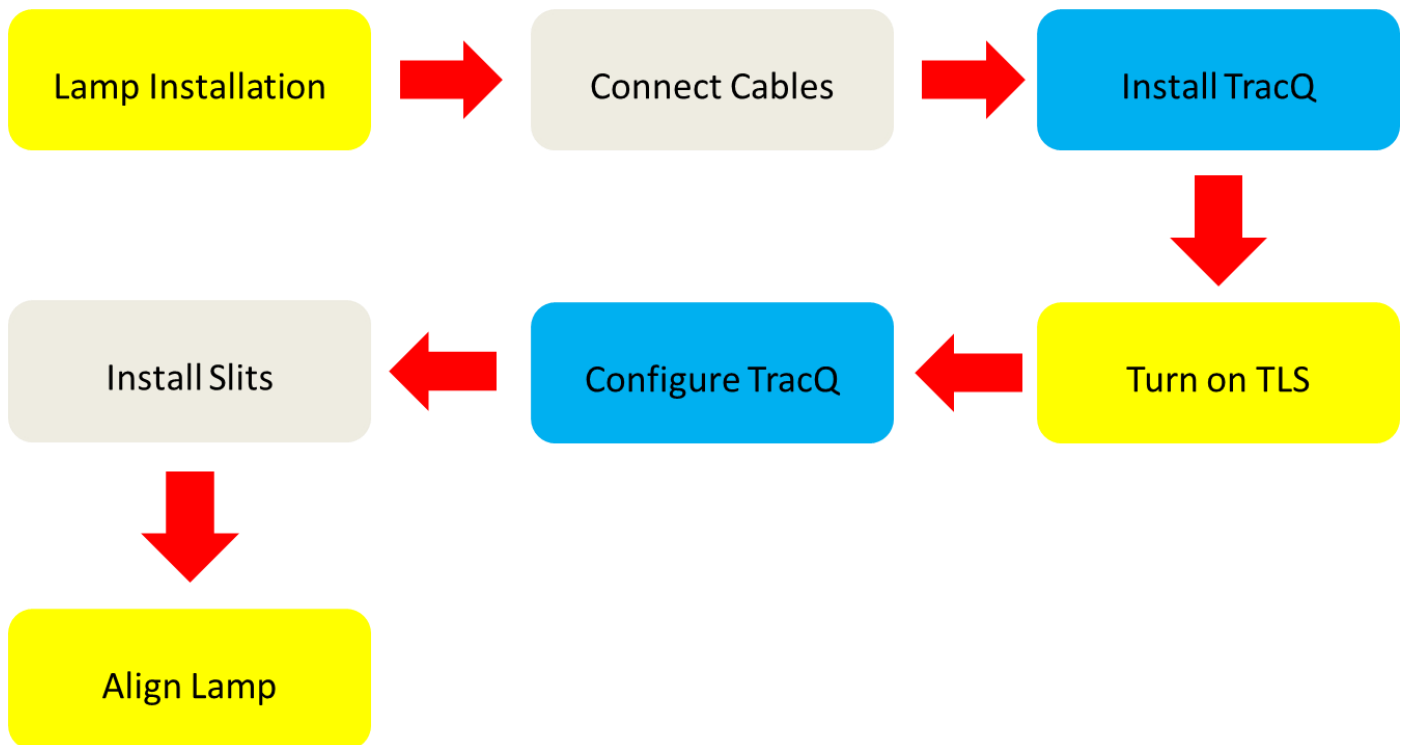

Figure 3: TLS Setup Process for Optimum System Performance

1. Lamp Installation. The TLS includes a 250 W QTH (TLS 130B-250Q) or 300 W Xe (TLS 130B-300X) lamp. To protect the fragile lamp during shipping, it was removed from the housing and packaged separately prior to shipment. This lamp must be installed into the housing before use.

2. Connect Cables. The following cables are included with the TLS:

- Cornerstone 130B Monochromator AC power cable
- OPS Series Power Supply AC power cable
- 70050 Lamp Housing Interconnection cable
- 70040 RS232 Communication and 70044 USB Communication cables

ELECTRICAL AND COMPUTER CONNECTIONS explains how to properly connect these cables and the necessary safety precautions that must be followed.

3. Install TracQ Basic software. **CHAPTER 3: SOFTWARE INSTALLATION** in the **TracQ Basic Spectroscopy Software User's Manual** explains how to install the program. Users may want to refer to **Section 2.3 SYSTEM REQUIREMENTS** of the **TracQ Basic Spectroscopy Software User's Manual** first to ensure their system meets the minimum requirements for installation.



4. Turn on TLS. Turning on the Cornerstone 130B Monochromator, OPS Series Power Supply, and igniting the lamp turns on all components of the TLS system. Figure 4 shows the On/Off switch of the Cornerstone 130B Monochromator. The  position indicates the monochromator is Off and flipping the switch to the  position turns on the monochromator.



Figure 4: The On/Off switch of the Cornerstone 130B Monochromator circled in red

5. Configure TracQ Basic software. **SOFTWARE CONFIGURATION** explains how to configure TracQ for each TLS system and provides an overview of the basic functions of the software. Users

who want to understand TracQ functions and capabilities in more detail should read the **TracQ Basic Spectroscopy Software User's Manual** included with the TLS.

6. **Install Slits. SLIT ADJUSTMENTS** explains where the fixed slit holders are located at the input and output ports of the monochromator and how to properly install fixed slits into these holders.
7. **Align Lamp. LAMP ALIGNMENT** explains how to properly align the lamp for both QTH (TLS 130B-250Q) and Xe lamp (TLS 130B-300X) versions of the TLS.

LAMP INSTALLATION

LAMP HANDLING PRECAUTIONS



CAUTION!

When installing the lamp, you **MUST**:

- Wear eye protection.
- Wear powder-free gloves.
- Make sure the power supply is turned off.

Read all warning labels and literature that were provided with the lamp and all literature provided with this system. The power supply must be unpowered before installing the lamp. Never touch the envelope of any lamp. If it is touched, clean it with isopropyl alcohol and a lint-free tissue such as a Kimwipe®.

In order to prevent contaminants from getting on the glass envelope, Oriel Instruments advises using powder free gloves while handling the lamp. Wearing goggles is also strongly advised. Use care when handling the lamp. Do not bend, flex, or otherwise exert any unnecessary force on the lamp. The lamp is under pressure and glass particles can act as projectiles if the lamp is broken.

Unpack the lamp carefully. Set aside the packing material and box, so that they can be used for lamp storage if the system is to be relocated at a later date (do not transport a lamp housing while the lamp is installed).

ACCESSING THE LAMP COMPARTMENT

The lamp position and reflector position have been pre-set at the factory. **Do not turn the grey end caps** when removing the door to the lamp compartment, as this will move the lamp position.

If the rear reflector or lamp position adjustment knobs are moved, it may reduce throughput and the accuracy of certain sensitive measurements, such as quantum efficiency or spectral responsivity

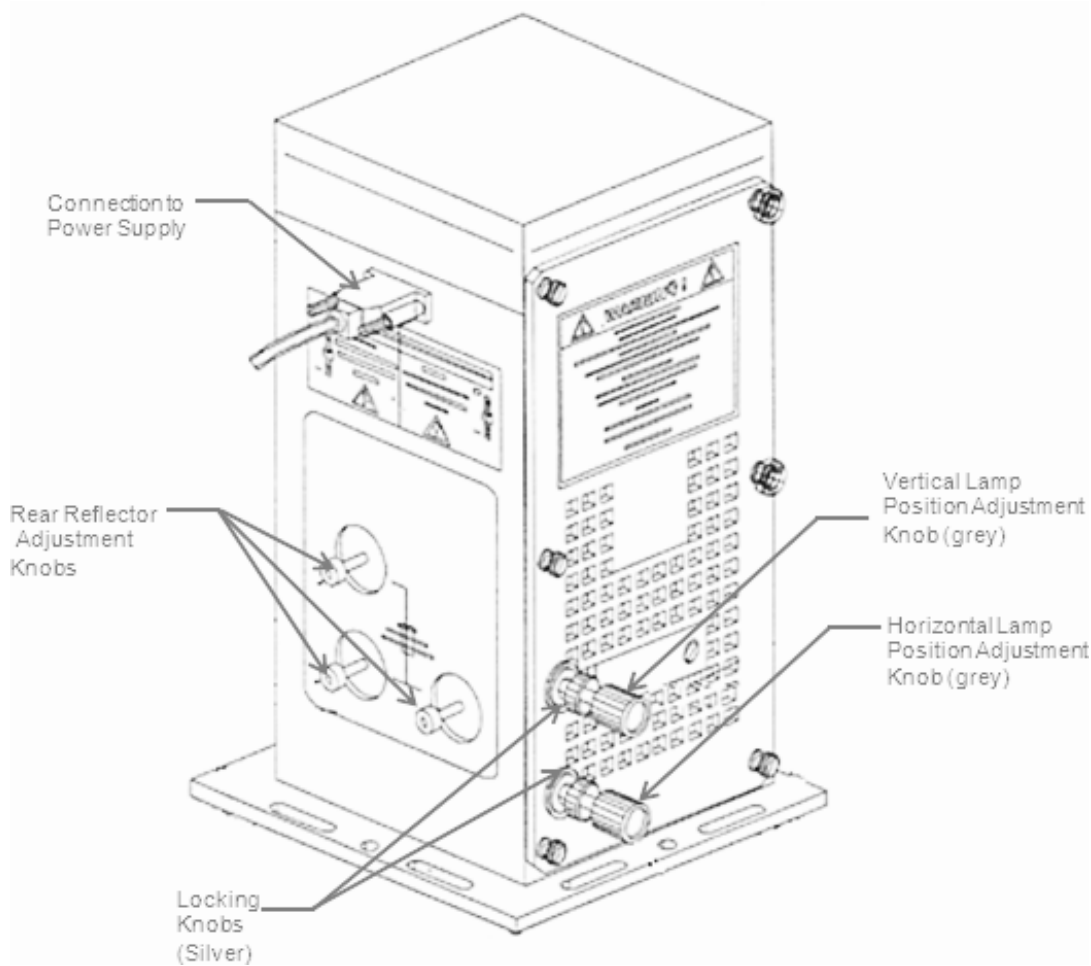



Figure 5: Lamp Housing Adjustment Controls

The lamp is packaged in its own protective box, to prevent shipping damage. The lamp housing door needs to be removed in order to install the lamp. Remove the two socket head cap screws in front of the lamp housing door using the hex wrench provided with the system.

	<p>WARNING</p> <p>Never attempt to ignite a Xenon lamp without being certain that the lamp has been installed into the housing. The resulting electrical arc will result in damage to the ignition circuit and may result in injury or death.</p>
---	--

To open the lamp housing, unscrew the six knurled black thumbscrews on the side of the housing to remove the access door as shown in Figure 6. It may be necessary to back off the knurled lock nuts on the lamp positioning adjustment screws.



Figure 6: Opening Lamp Housing Door

XENON LAMP INSTALLATION

(See page 21 for QTH Lamp Installation)

Remove the twist tie or cable tie holding the sensor block in place and loosen the thumbscrew on the lamp mount as shown by the arrows in Figure 7.

Note: always use powder-free gloves when handling a lamp. After a lamp is ignited, finger oils left on the lamp will etch into the envelope material, damaging the glass.

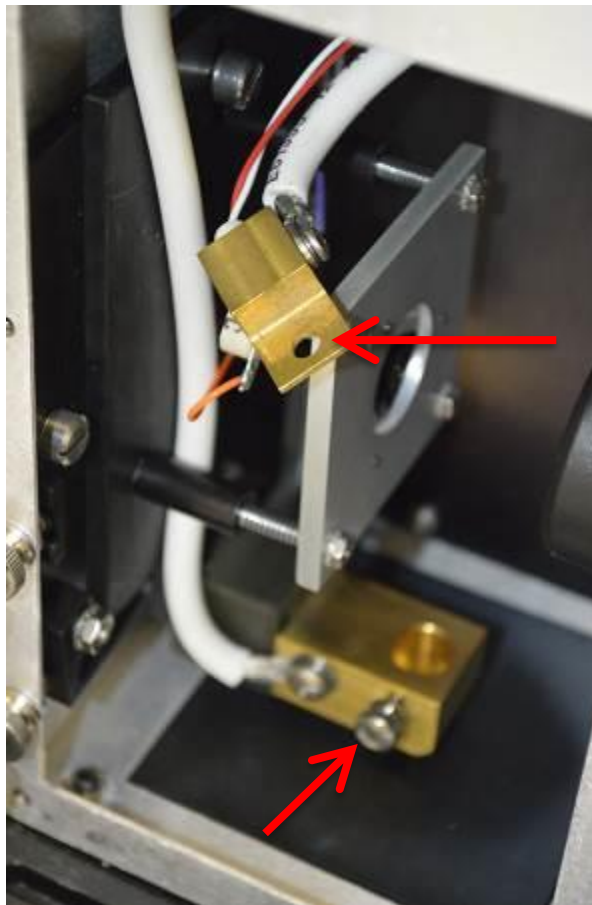

Figure 7: Preparation for arc lamp installation

The lamp shipped with the system comes with a brass piece connected to the bottom lamp terminal (cathode) and a knurled thumbscrew at the top terminal (anode). The brass piece is referred to as a socket adapter. The anode of the lamp is marked with a “+” on the terminal.

A replacement lamp comes with knurled thumbscrews at both terminals. When installing a replacement lamp, the socket adapter must be removed from the previously used lamp and installed in place of the cathode thumbscrew. The socket adapter installation is shown in Figure 8. The cathode is the bottom (negative) terminal.

Note: The lamp shown in Figure 8 has a wire attached to the lamp envelope. This is what is referred to as a “starter wire”. Its purpose is to help with achieving ignition. Do not remove this wire.



Figure 8: Socket Adapter Installation

Remove the knurled thumbscrews that come installed on the anode end of the lamp, as shown in Figure 9.



Figure 9: Lamp Prepared for Installation

Before installing the lamp, refer to Figure 10 and double check that the socket adapter is installed on the cathode. Running a lamp installed backwards will result in very premature failure, which is not covered under warranty.

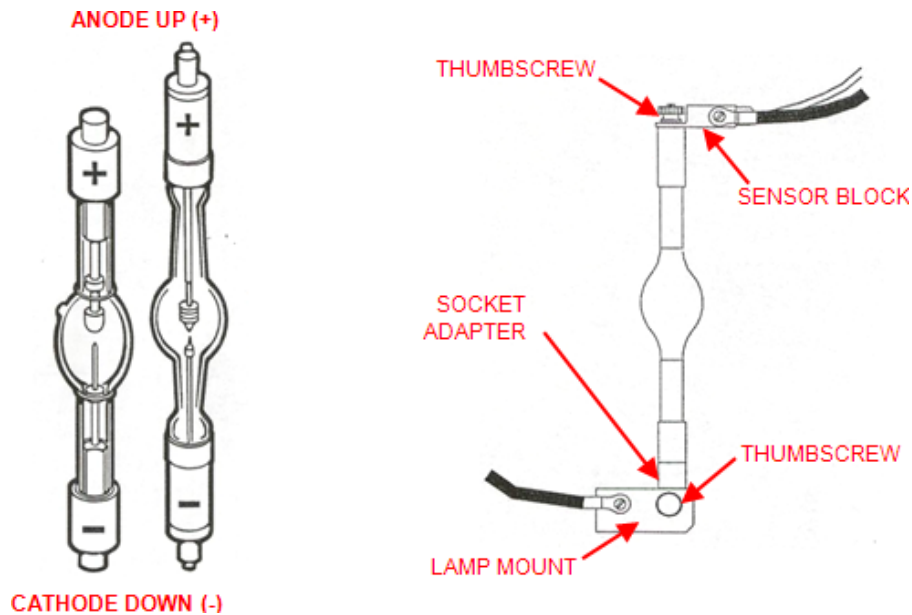

Figure 10: Arc Lamp Orientation

Place the sensor block onto the threaded post at the anode (+ terminal) of the lamp. Loosely secure the sensor block to the lamp with the knurled thumbscrew that came with the lamp as shown in Figure 11.

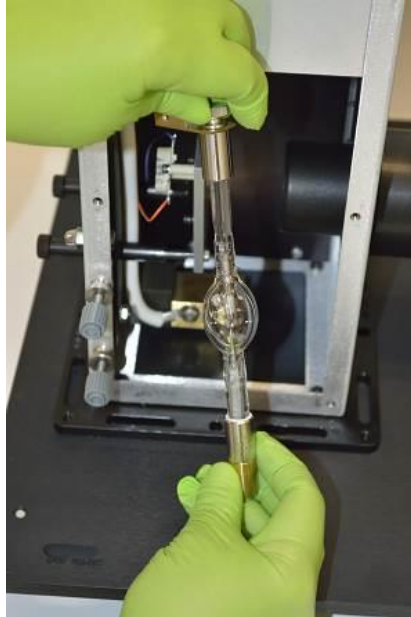

Figure 11: Attaching Sensor Block

Carefully place the lamp into the lamp mount with the cathode side down. This is the end of the lamp where the brass socket adapter has been installed by the factory. The endcaps of the lamps should not be subjected to strain, as the lamp seals are fragile.

If the lamp includes a starter wire, rotate the lamp so that the wire is facing towards the back of the lamp housing. The back of the lamp housing is where the baffle covers the fan, directly opposite of the door opening.

After the lamp has been oriented correctly, be sure to fully tighten the thumbscrew on the lamp mount and tighten the thumbscrew at the top of the lamp.

Replace the door of the lamp housing, making sure to engage the safety interlock tabs. Secure the door in place using the six plastic fasteners. Use all of them to prevent light leakage. Reinstall the socket head cap screws in front of the door, to secure the lamp housing to the mounting plate.

Note: Under no circumstances should the interlock tabs be removed, or the interlock circumvented or defeated. Note that the lamp housing cannot be operated without its door being secured in place. If the door is not secured in place then an “Interlock Open” error will appear on the power supply display as shown in Figure 12.



Figure 12: Interlock Open Error Message of the OPS Series Power Supply



Figure 13: Tightening Thumbscrew



Figure 14: Xenon Arc Lamp Installed

QTH LAMP INSTALLATION

(See page 16 for Xenon Lamp Installation)

Note: always use powder-free gloves when handling a lamp. After a lamp is ignited, finger oils left on the lamp will etch into the envelope material, damaging the glass. A Quartz Tungsten Halogen (QTH) lamp is very delicate, so it should not be subjected to excessive strain or it may break.

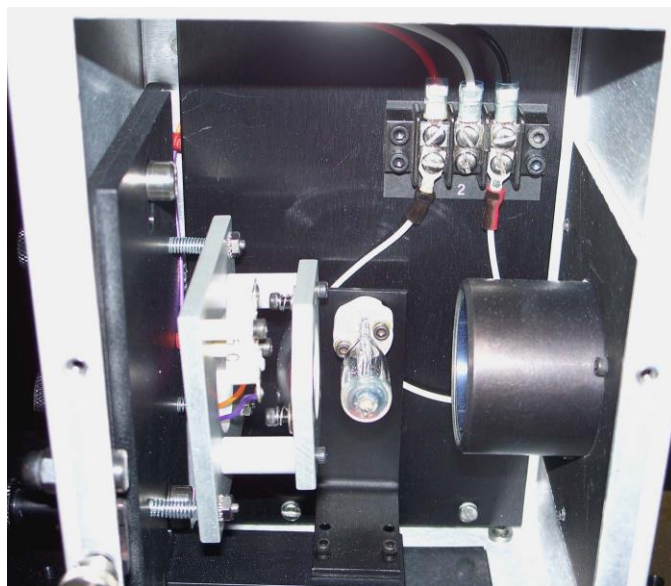

Figure 15: QTH Lamp Installation

Mount the lamp in the socket adapter by carefully lining up the two pins of the lamp with the socket and pushing in slowly without excessive rocking back and forth.

Replace the door of the lamp housing, making sure to engage the safety interlock tabs. Secure the door in place using the six plastic fasteners. Use all of them to prevent light leakage. Reinstall the socket head cap screws in from of the door, to secure the lamp housing to the mounting plate.

Note: Under no circumstances should the interlock tabs be removed, or the interlock circumvented or defeated. Note that the lamp housing cannot be operated without its door being secured in place. If the door is not secured in place, then an "Interlock Open" error will appear on the power supply display as shown in Figure 12.

ELECTRICAL AND COMPUTER CONNECTIONS

Before powering up the system for the first time, it is strongly suggested to have a qualified electrician verify the wall socket to be used with the TLS System meets the requirements for operation as noted.

Before making any electrical connections, verify the front panel power switches are in the off position for the monochromator and lamp power supply.

	<p>WARNING</p> <p>To avoid electric shock, connect the instrument to properly earth-grounded, 3-prong receptacles only. Failure to observe this precaution can result in severe injury or death.</p>
--	---

The line voltage requirements are as follows:

Lamp Power Supply	95 to 264 VAC, 50-60 Hz
Monochromator Power Adapter	100 to 240 VAC, 47-63 Hz

The Tunable Light Source system conforms to CE standards for both safety and EMC. During normal use, this equipment will not pose any electrical hazards to the user. Read all warnings before installing or operating this system. If there are any questions or concerns, contact Oriel Instruments or the regional sales representative for Newport.

	<p>ELECTRICAL SHOCK</p> <p>Never attempt to open the lamp power supply or monochromator power adapter. These items do not contain any user serviceable parts. Failure to follow this warning can result in severe injury or death.</p>
---	---

The monochromator's power adapter connects to an AC wall socket and supplies DC voltage to the instrument. Do not open the monochromator cover and attempt to work inside without first turning the instrument off and disconnecting the power cord from the AC mains.

The ribbon cable connecting the monochromator to the filter wheel is installed before the system ships out. The monochromator provides power to the filter wheel and allows the user to select which filter is placed in the optical path.

Ensure the monochromator power switch is in the off position (marked as O). Ensure the power adapter is connected to the rear panel port labeled POWER of the monochromator, shown in Figure 16. Insert the power cord provided into the power adapter and connect to the AC mains.

The TLS130B series come with a USB 2.0 cable and a RS232 cable. Replacement cables are available from Newport at <https://www.newport.com/f/serial-communication-cables>.

Cable Type	Newport Part Number
RS232	70040
USB	70044

Connect the USB or RS-232 cable to the appropriate rear panel port of the monochromator shown in Figure 16. Plug the other end of the cable into the computer only after the TracQ Basic software has been installed.



Figure 16: Rear panel of the CS130B monochromator

Connect the lamp housing interconnection cable to the lamp housing, as shown in Figure 17. It is extremely important that the cable connections be completely tightened, to prevent arcing.

Ensure the switch for the lamp power supply is in the off position. Attach the other end of the interconnection cable to the port marked **OUTPUT 1** (Circled in Red) on the back of the power supply, as shown in Figure 18. Again, it is extremely important that the cable connections be completely tightened. Plug the power cord provided into the back of the power supply. Connect the other end of the power cord to the port marked AC IN as shown in Figure 18.



Figure 17: Lamp Housing Connection



Figure 18: Power Supply Connections

LAMP STARTUP

The power supply has been factory configured for proper operation with the TLS system. However, these settings should be confirmed and adjusted on the user's end (if necessary) before attempting to start/ignite the lamp of the TLS. Confirm the settings of the OPS Power Supply are configured as listed in the table below, for both Power and Current Operating Modes:

TLS Model	Power Supply Operating Mode			
	Power		Current	
	P_{set}	P_{max}	I_{set}	I_{max}
TLS130B-250Q	250 W	275 W	10.42 A	11.46 A
TLS130B-300X	300 W	330	15 A	16.5 A



Figure 19: OPS Series Power Supply Front Panel

The following screen will appear on the power supply's LCD upon powering up the OPS Power Supply:

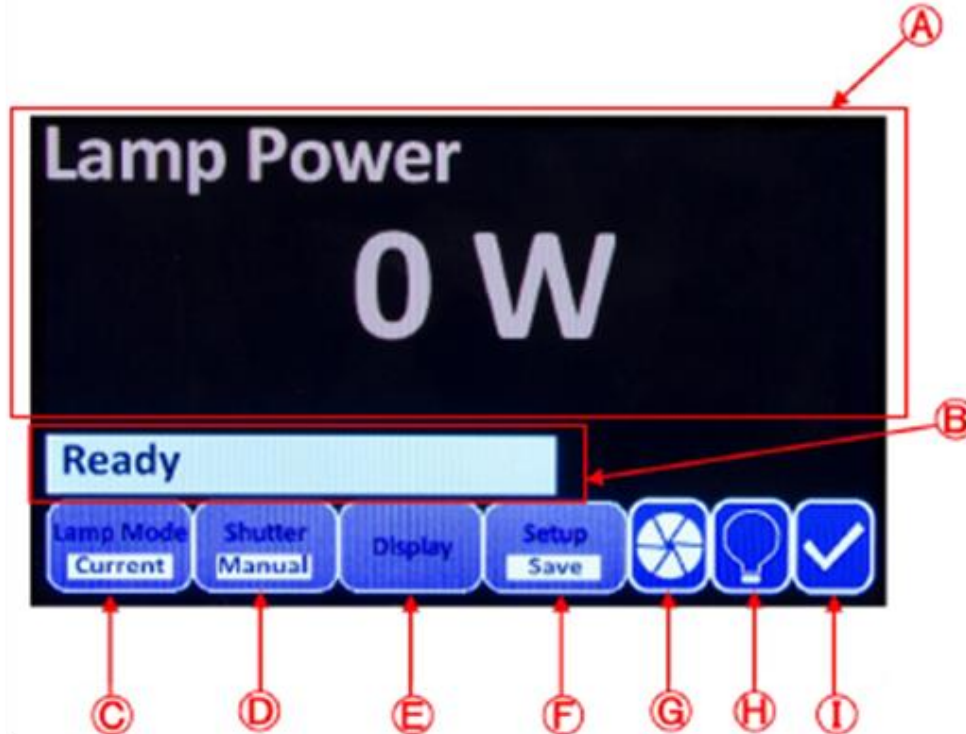

Figure 20: The LCD display of OPS power supply

- A.** The main section of the LCD screen displays the desired parameter as selected by the user and will be used for menu navigation.
- B.** This portion of the LCD screen displays a “Ready” status indicating the power supply and related components (lamp housing, lamp housing interconnection cable) are prepared for lamp ignition, or displays “Interlock Open,” indicating a problem with the system setup. Similar error messages such as “Cooler Not Ready” when using the LIK-LMP Light Intensity Controller kit and “Function Not Available” may also be displayed here. The meaning of these error messages and troubleshooting techniques are explained in the relevant portions of this manual.
- C. Lamp Mode.** The operating mode as designated by the user will be displayed by this indicator.
- D. Shutter.** The setting of the shutter, manual or timed, as designated by the user will be displayed here. This feature is disabled on the TLS130B series.
- E. Display.** Pressing the horizontal menu button under this icon will reveal the vertical menu listing the display options available by the OPS-A Model Power Supply.
- F. Setup.** Pressing the horizontal menu button under this icon will allow the user to Save and Load preferred settings, reset the number of hours the OPS-A has been recording for the current lamp in use, and access other functions of the power supply. More details on the functions accessible with the menu button under this icon are explained throughout this manual.

G. Shutter Indicator. This icon displays the open/close status of the shutter. This feature is disabled on the TLS130B series.

H. Lamp Indicator. This icon displays the ignition status of the lamp.

I. This icon will display either a Check Mark, indicating lamp housing connections and lamp housing door are properly secured, or an Exclamation Point, indicating the connections and/or door previously referenced need to be re-examined for secure connection(s)

To start the lamp, first switch on the power supply using the switch marked **POWER** located on its front panel as shown in Figure 19. Then, press the **LAMP** button on the front panel of the power supply.

A Xenon lamp will go to full power immediately after it has been ignited. A QTH lamp will gradually ramp up to the operating current to minimize the stress on the lamp. **All types of lamps must be allowed to fully warm up and stabilize prior to data acquisition.**

For TLS systems with an arc lamp (TLS130B-300X) it is recommended to operate the lamp in **Constant Power mode** for better long-term output stability and lamp lifetime.

For TLS systems with a QTH lamp (TLS130B-250Q) it is recommended to operate the lamp in **Constant Current mode** for consistent light intensity output throughout the lifetime of the lamp. Please see the OPS Power Supply Manual for more information on operating the OPS Series Power Supply.

In order to achieve the maximum light output from the lamp, it is recommended the lamp be operated at but not exceed the voltage and current values shown in the table below:

Model	Power	Current
TLS130B-250Q	250 W	10.42 A
TLS130B-300X	300 W	15 A

The lamp housing is cooled by its own fan. The fan speed is regulated by the electronics built into the lamp housing. An additional safety shutoff switch is also present to turn off the lamp in case of overheating.

When one is finished with using the system, use the **LAMP** button to turn off the lamp. While the power switch is left on, the lamp housing fan will switch to high speed to cool the lamp. This cooling process takes up to 20 minutes. After this time has elapsed, the fan shuts off.

Note: Excessive ignition places stress on the lamp, wears away the arc lamp electrodes and will reduce lamp life. Always allow the lamp to cool off completely before re-igniting it. If there are any difficulties igniting the lamp, refer to the portion of this manual marked **SECTION 9: TROUBLESHOOTING** for possible causes of lamp ignition failure and power supply error messages.

SOFTWARE CONFIGURATION

Follow the instructions detailed in the user manual of TracQ Basic to utilize the software. If TracQ software hasn't installed on the computer then please review **Chapter 3: SOFTWARE INSTALLATION** in the **TracQ Basic Spectroscopy Software User's Manual**.

The software is used to set up the monochromator's grating and filter parameters. After the setup has been completed, TracQ Basic allows the user to select the desired wavelength of monochromatic light.

Note: the monochromator is also capable of emitting white light, by selecting a wavelength of 0 nm.

Before launching TracQ Basic, the instruments to be used must be connected to the computer, their drivers functioning correctly (if USB) and the instruments switched on. If a detection instrument is not installed, the software functionality is limited to loading scans and adjusting monochromator parameters, such as calibration factors, shutter status, etc.

When starting the software for the first time, prompts will appear to select the instrument libraries. When the Monochromator Library window appears, click on the instrument library folder corresponding to the instrument, then click "Select Folder". Please refer to the table below to select the correct monochromator folder corresponding to the CS130B interface connection you chose.

Interface	Library Folder
RS232	CS130B_RS232
USB 2.0	CS130B_USB

If it is decided to not select instrument libraries, click "**Cancel**". TracQ Basic provides the opportunity to select or change instruments at any time.

TracQ displays the instrument status as indicators on the main window of the software, as seen in Figure 21. When the correct instruments are selected and TracQ is successfully able to establish communication, the indicators are green. If instruments cannot be found, the indicators are red.

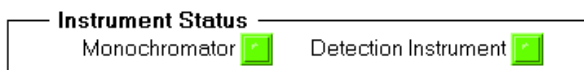
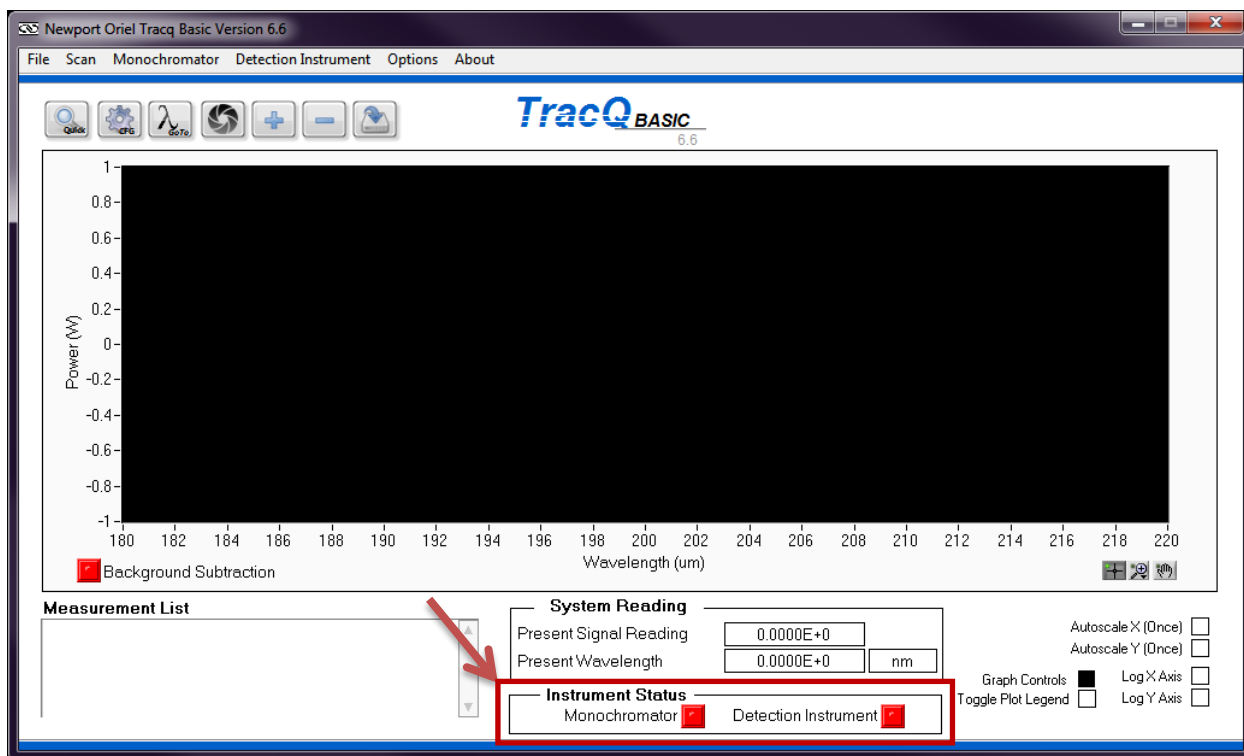

Figure 21: Instrument Status Indicators

In order to perform scans and acquire data using TracQ Basic, a detection instrument is required. Please refer to the TracQ Basic User's Manual included with the software for a list of compatible detection instruments and applications.

ESTABLISHING MONOCHROMATOR COMMUNICATION

These instruments are available with two communication options for interfacing with a computer: RS232 or USB. To change the default communication setup, go to the pulldown menu Monochromator → Communication. Enter the Com Port number, then click “OK”. This menu choice is not available with USB instruments.



Figure 22: RS232 Communication Setup

The monochromator must be connected to the computer with the USB or RS232 cable and powered on before opening the software application.

When starting the TracQ Basic software for the first time, prompts guide the user to select the detection instrument and monochromator for the system. If no detection instrument is to be used, click Cancel. Otherwise, select the instrument based on the instructions included with the software or detection device.

To set up the monochromator, go to the pulldown menu named “Monochromator”, shown in Figure 23.

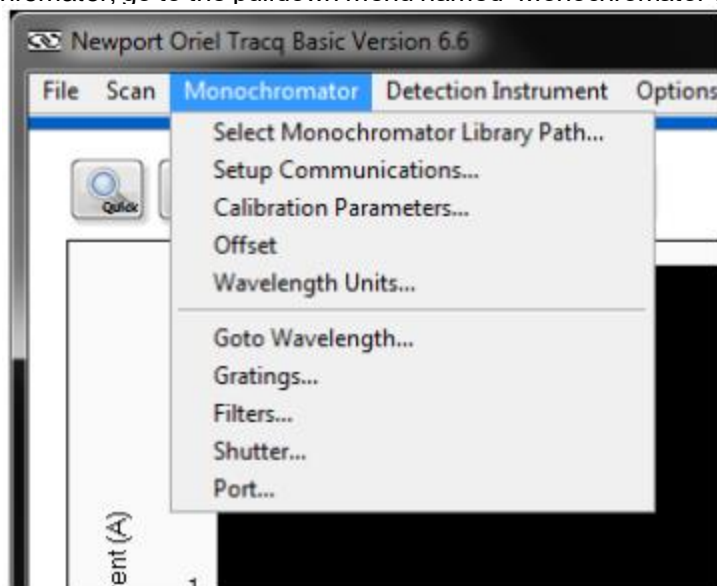

Figure 23: Monochromator Configuration Menu

To select the Tunable Light Source monochromator, navigate to the following folder:

C:\Program Files\Newport – Oriel Instruments\TracQ Basic.

Please refer to the table below to select the correct monochromator folder for TLS model:

Interface	Library Folder
RS232	CS130B_RS232
USB 2.0	CS130B_USB

Verify that the indicator on the front panel of the software is green for the monochromator and detection instrument, if one is utilized.

SHUTTER CONTROL

An electronic shutter is integrated into the CS130B monochromator. It is mounted inside the housing at the input port. This shutter is normally closed. To access the shutter control setting, go to the pulldown menu Monochromator → Shutter, choose “Open” or “Closed” and click “OK”.

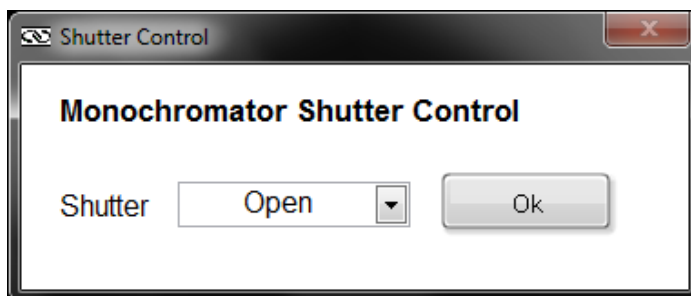

Figure 24: Shutter Control

SELECTING WAVELENGTH UNITS

TracQ Basic scans may be taken, and data displayed in nanometers, micrometers or wavenumber. The default value is nanometers. To select the wavelength units, go to the pulldown menu Monochromator → Wavelength Units.

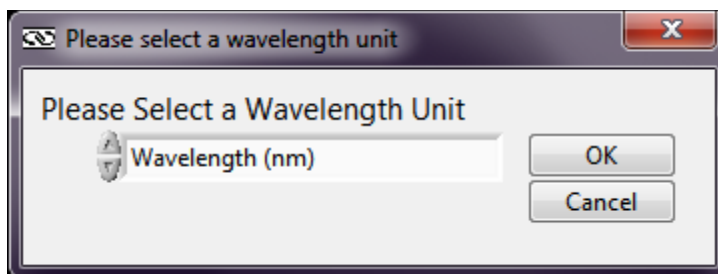

Figure 25: Selecting Wavelength Units

SETTING MONOCHROMATOR WAVELENGTH OUTPUT

Selecting a specific wavelength for the monochromator to output is useful when positioning a detector or sample. The default wavelength is 555 nm, as it is very easily seen by the human eye. Go to the pulldown menu Monochromator → Goto Wavelength. Click on the “555 nm” icon or type in another wavelength if desired. Note that this may also be accessed from the Lambda icon in the main application window.

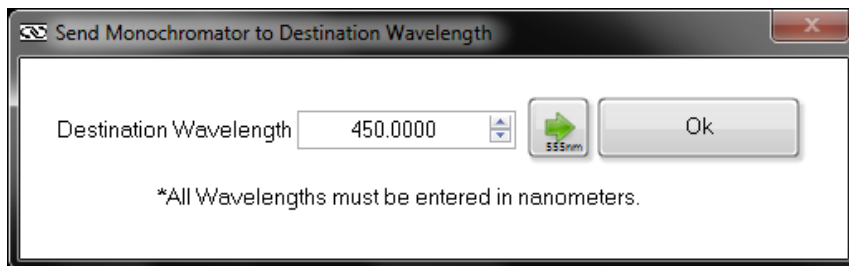

Figure 26: Selecting a Monochromator Output Wavelength

MONOCHROMATOR OFFSET

An offset may be introduced to the monochromator’s wavelength, if required. A light source with a known spectral peak must be utilized. Go the wavelength of the peak. If the actual wavelength differs from the wavelength displayed by the monochromator in TracQ Basic, go to the pulldown menu Monochromator → Calibrate. Enter the actual wavelength of the peak and click “OK”.

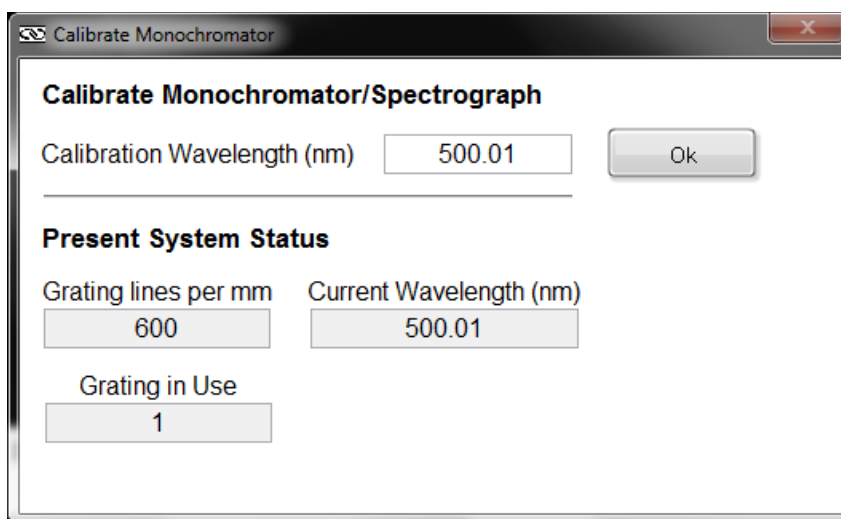

Figure 27: Monochromator Wavelength Offset

MONOCHROMATOR CALIBRATION PARAMETERS

Each instrument comes with calibration parameters for all gratings installed. To view this information, go to the pulldown menu Monochromator → Setup Parameters. Unless a field calibration was performed, or an offset introduced, these values should match the values contained in the calibration data supplied with the instrument.

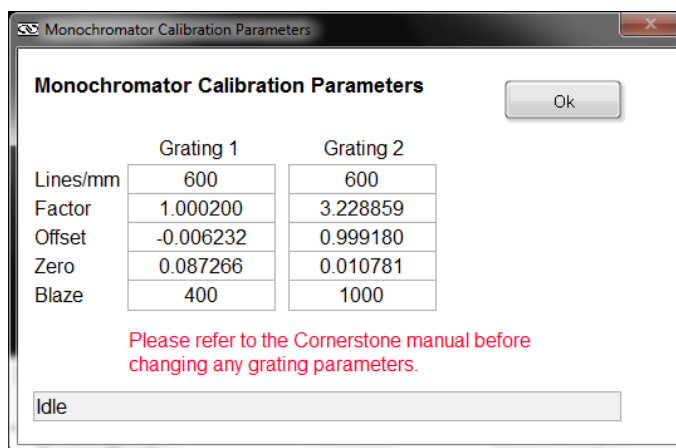

Figure 28: Monochromator Calibration Parameters

GRATING SELECTION PARAMETERS

In order to produce monochromatic light over the full wavelength range specified for a Tunable Light Source, Oriel’s Cornerstone™ 130B monochromator contains two ruled diffraction gratings. Each grating is capable of working over a certain wavelength range based upon its design. By setting the grating parameters in the TracQ Basic software, the monochromator will automatically select the appropriate grating for any desired wavelength.

Go to the pull-down menu Monochromator → Gratings...

Adjust the settings as shown in Figure 29.

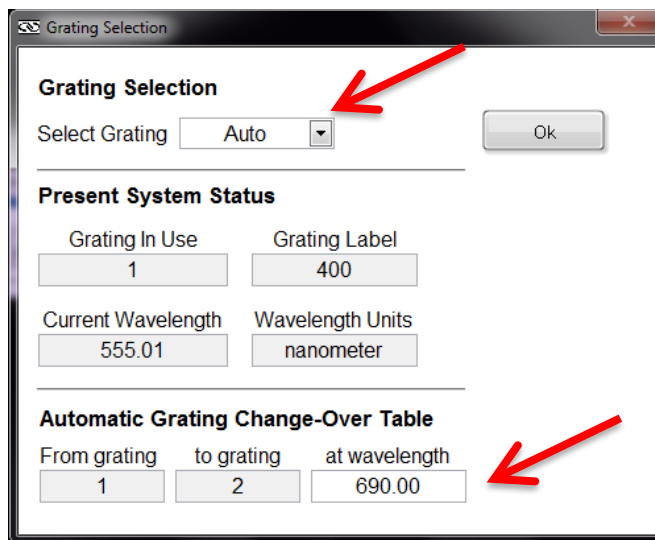

Figure 29: Grating Selection Table

FILTER SELECTION PARAMETERS

In order to ensure that the light produced by the Tunable Light Source system is monochromatic, it is necessary to incorporate optical filters into the design. The physics of diffraction gratings is such that higher order wavelengths need to be blocked. The filters selected for the Tunable Light Source have been chosen to block unwanted wavelengths.

By setting the filter parameters in the TracQ Basic software, the monochromator will automatically select the appropriate filter for any desired wavelength.

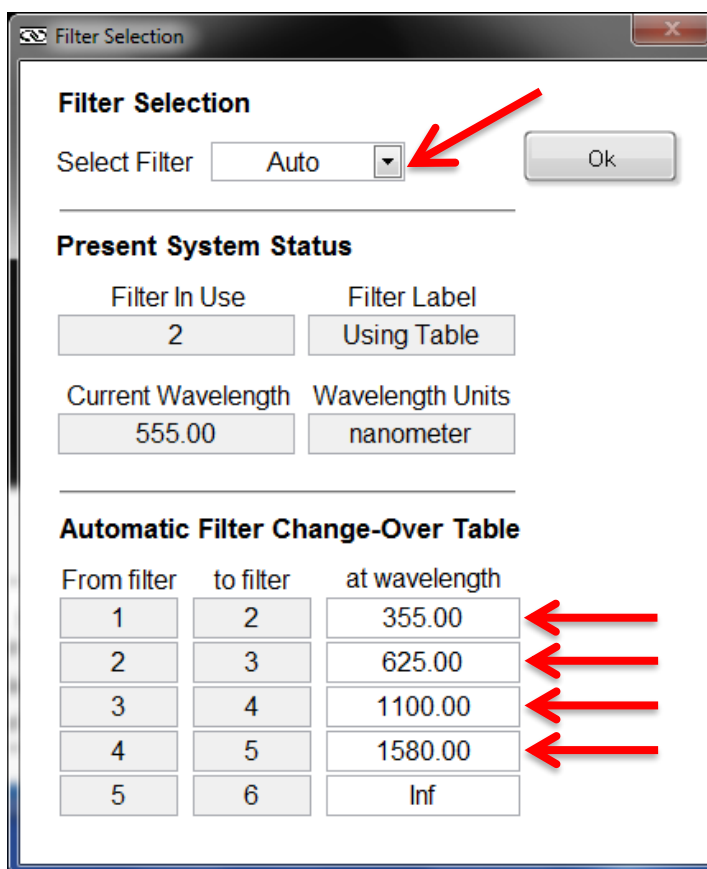

Figure 30: Filter Selection Table

SLIT ADJUSTMENTS

Fixed slit holders are mounted to the input and output port of the monochromator. Fixed slits are a low-cost alternative micrometer adjustable slits and provide excellent repeatability. The TLS includes the following slits:

Fixed Slit Model	Width	Height
77217	280 μm	18 mm*
77216	600 μm	18 mm*

*Actual slit height is 18 mm, usable height is 12 mm.

The fixed slit holder at the input port of the monochromator is located between the filter wheel and the monochromator. This can be seen in Figure 31. The fixed slit holder at the output port of the monochromator is located on the output end of the monochromator preceding the focusing optics. This can be seen in Figure 32.



Figure 31: The fixed slit holder at the input port of the monochromator.



Figure 32: The fixed slit holder at the output port of the monochromator.

Remove the fixed slits (if necessary) currently in the fixed slit holders at the input and output ports of the monochromator and simply insert the desired slit width.

When inserting a slit into its holder, it is important that the notch at the corner of the slit be oriented upward, as shown below. Inserting a slit upside down will prevent the slit from being fully inserted into the fixed slit holder and block the path of light in and/or out of the monochromator. It is also important to install fixed slits of matching dimensions at the input and output ports of the monochromator. A wider slit width at the input port of the monochromator with respect to the slit width at the output port results in more stray light input to the instrument. A wider slit width at the output port of the monochromator with respect to the slit width at the input port will not result in increased throughput.



Figure 33: A 280 μm fixed slit with the notch oriented upward properly for installation

The following fixed slit models/slit widths are also available separately from Oriel Products. See the Newport website (<http://www.newport.com>) for ordering information.

Part Number	Width	Height
77222	10 μm	2 mm
77220	25 μm	3 mm
77219	50 μm	6 mm
77218	120 μm	18 mm*
77215	760 μm	18 mm*
77214	1.24 μm	18 mm*
77213	1.56 μm	18 mm*
77212	3.16 μm	18 mm*
77211	6.32 μm	18 mm*

*Actual slit height is 18 mm, usable height is 12 mm.

The tunable light source should not be operated without fixed slits installed. Operating the TLS without fixed slits installed will result in light leakage through the fixed slit holders at the input and output ports of the monochromator and failure of the TLS to output monochromatic light due to an excessively large output aperture of the monochromator. An example of this can be seen in Figure 34.

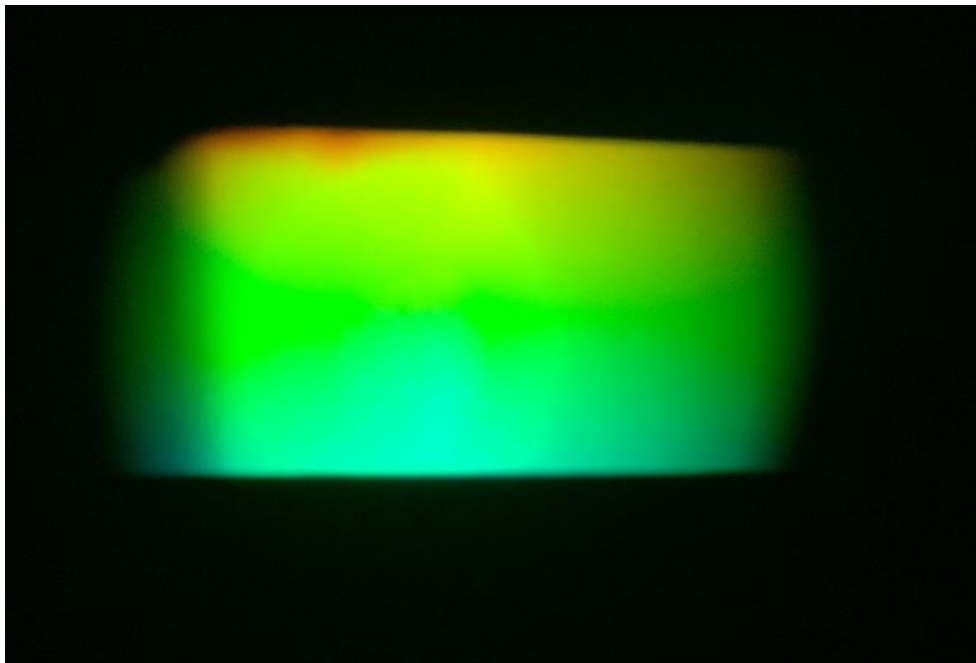

Figure 34: The output of the TLS set to 550 nm, but no fixed slits installed.

LAMP ALIGNMENT

The Newport Tunable Light Source family of products is designed to provide high-quality light output. To achieve optimal performance, proper alignment of the lamp is required. Lamp alignment consists of properly positioning the lamp, adjusting the lamp housing rear reflector position and locking the lamp housing condenser lens assembly in its correct location.

Lamp alignment may be performed when receiving the Tunable Light Source (TLS), any time the lamp is removed and reinserted (such as when transporting the unit), and when installing a replacement lamp.

Failure to align or properly align the lamp with the focusing lens of the lamp housing results in:

- An asymmetrical, non-uniform output beam
- Diminished output intensity

Always wear eye protection suitable for use with UV radiation during the lamp alignment process. The light output will heat up any surface or object to which it is aimed, particularly when the light is focused onto a small area. The lamp housing's condenser assembly will become hot while the lamp is on and will remain hot for some time after the lamp is turned off.

Do not leave the lamp unattended while performing this procedure. Ensure the light cannot cause injury or damage to persons or objects in the general area.

A flat, non-reflective vertical surface is required as a backdrop to image the output of the TLS when performing the alignment procedure. Ensure the surface is non-flammable and will not be damaged by the heat produced from the lamp. To view the image clearly, it may be necessary to turn off the room lighting.

This procedure applies to the following Tunable Light Sources. The exact steps required to perform the lamp alignment depend on the type of lamp being utilized. Refer to the section in this procedure specific to the lamp type noted in the table below.

Model	Lamp Type
TLS130B-300X	Xenon Arc (Xe)
TLS130B-250Q	Quartz Tungsten Halogen (QTH)

Prior to turning on the TLS, the system must be inspected to confirm the lamp is installed, the lamp housing door is secured in place using all hardware provided and the lamp housing interconnection cable to the power is firmly connected to both the lamp housing and the power supply.

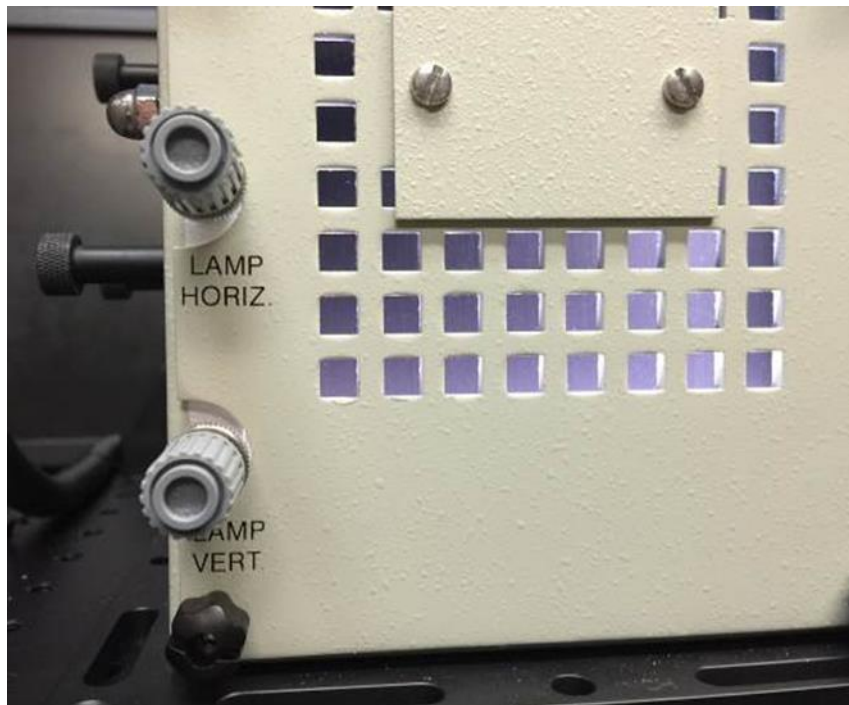

Figure 35: Lamp horizontal and vertical position adjustment knobs at the lamp housing door.

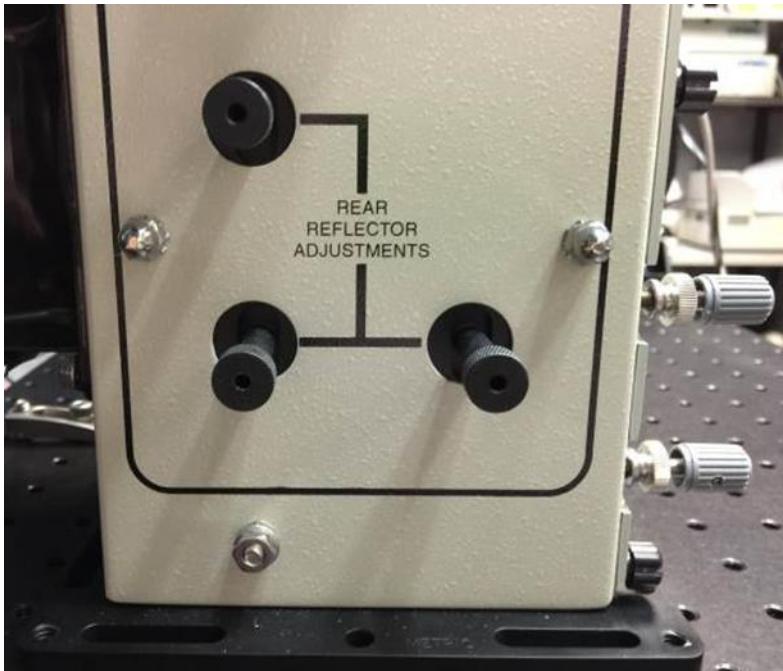

Figure 36: Rear reflector adjustment knobs on the side of the lamp housing.



Figure 37: Condenser lens assembly adjustment knob and adjustment lever at output of lamp housing.

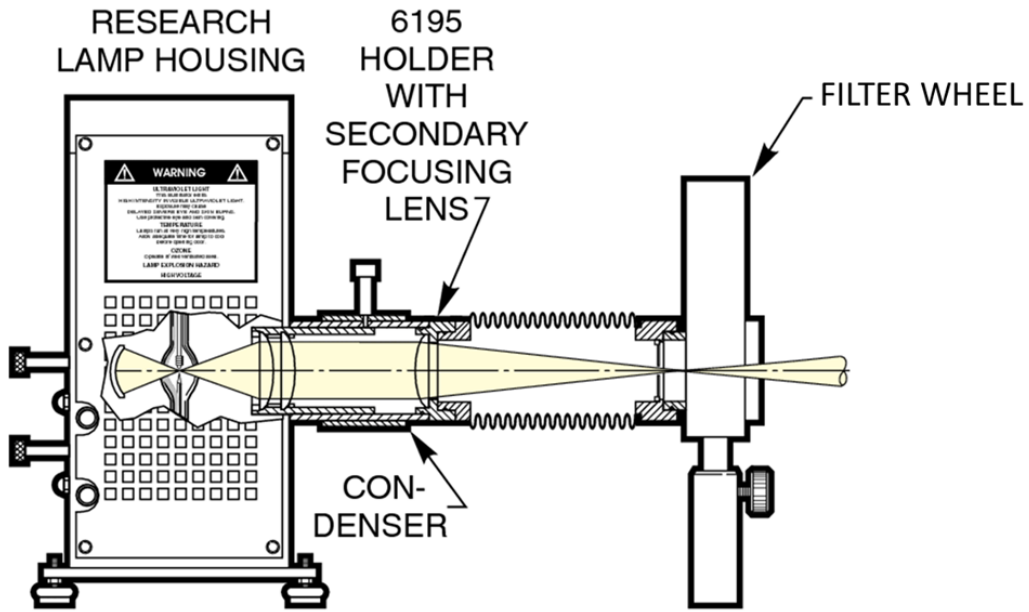

Figure 38: The light path and the optics of the TLS starting from the lamp to the filter wheel.

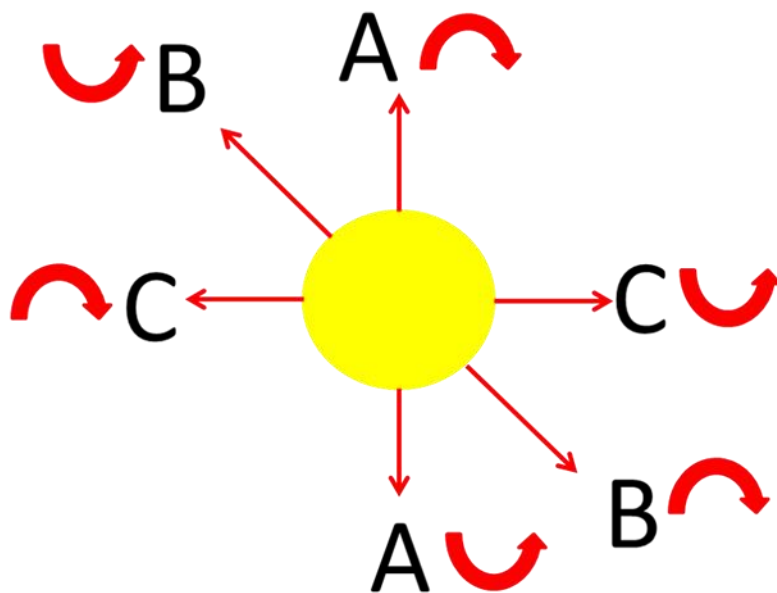
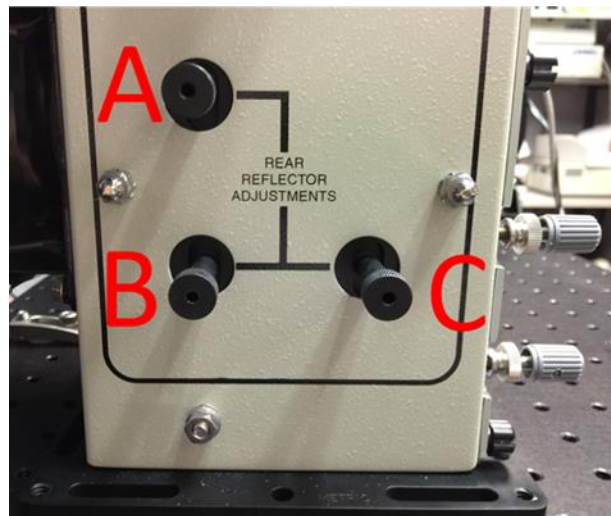

Figure 39: The yellow image at the right represents the secondary image of the QTH/Arc Lamp from the rear reflector of the lamp housing. To move this secondary image in the desired direction, rotate each Rear Reflector Adjustment knob as indicated in the image on the right.

QTH LAMP ALIGNMENT

(See page 46 for Xenon Lamp Alignment)

During the lamp alignment process, the lamp must be operated at its rated operating power or current. This is required in order to achieve a light output bright enough to visibly confirm each step of the lamp alignment procedure has been completed correctly. For QTH lamps, it is recommended that the power supply be operated in Constant Current mode, to allow for a consistent light intensity output throughout the lifetime of the lamp. The appropriate settings are noted in the table below.

Model	Power	Current
TLS130B-250Q	250 W	10.42 A

The input and output slits inserted into the fixed slit holders of the monochromator should be 600 μm , in order to allow the most light output from the TLS.

1. Turn on the TLS power supply and verify the settings shown in the table.
2. Connect the monochromator to a computer with TracQ Basic, Oriel Mono Utility or Mono Term software installed. The optional model 74009 hand controller may be used if a computer is not present.
3. Turn on the monochromator. Use the software or hand controller to go to wavelength "0".
4. Turn on the TLS lamp.

5. Position the backdrop a few inches from the output of the TLS. The backdrop must be placed at a distance the full output beam of the TLS can be seen.
6. Loosen the adjustment lever on the condenser lens assembly shown in Figure 37, by turning the adjustment knob at the top of the lever counterclockwise, so that it can be moved closer to or farther from the lamp housing. The loosened adjustment lever may be pushed or pulled so that it rotates about the cylindrical condenser lens assembly.
7. Move the adjustment lever so that it rotates about the cylindrical condenser lens assembly until the filament of the QTH lamp can be clearly seen on the backdrop placed in front of the TLS. The final position of the Adjustment Lever should be at the position which outputs the sharpest filament image on the backdrop, which is usually closest to the lamp housing as possible. The spiral shape of the lamp filament should be visible on the backdrop, as shown in Figure 40. This image is referred to as the "primary image".
8. Tighten the condenser adjustment knob to lock it into position.

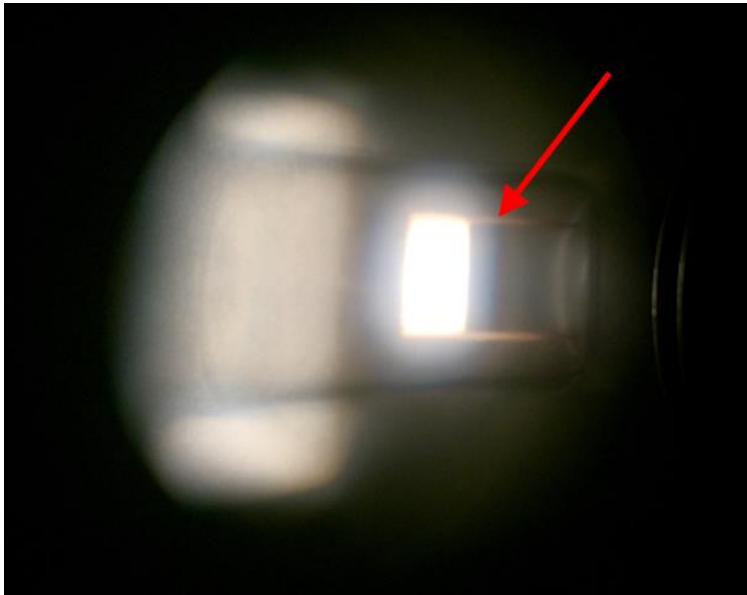

Figure 40: Primary image of QTH lamp filament after adjusting condenser lens assembly.

9. Rotate the grey horizontal and vertical lamp position knobs to move the primary image of the filament until it is horizontally and vertically centered within the circular output of the TLS.
10. When the primary filament image is centered, lock both lamp position adjustment knobs in place by tightening the silver locking screws behind each grey knob. Rotate the silver locking screws clockwise to tighten.
11. A reflector is located behind the lamp inside the lamp housing. The position of the reflector is adjusted using the knobs located on the side of the lamp housing, as shown in Figure 41 the lamp's reflected image is referred to as the "secondary image".
12. Figure 41 shows the lamp's primary image in the red box and the secondary image in the green box. Using the reflector adjustment knobs, ensure the secondary image is as sharp as possible. This may require loosening the condenser lens assembly adjustment knob and defocusing the primary image of the lamp filament, in order to achieve a sharper image of the filament's secondary image. Then overlay or superimpose the reflector's secondary image of the lamp onto the primary image of the lamp filament (see Figure 42). See Figure 39 for reference on how the secondary image is displaced relative to which knob is adjusted in each direction.

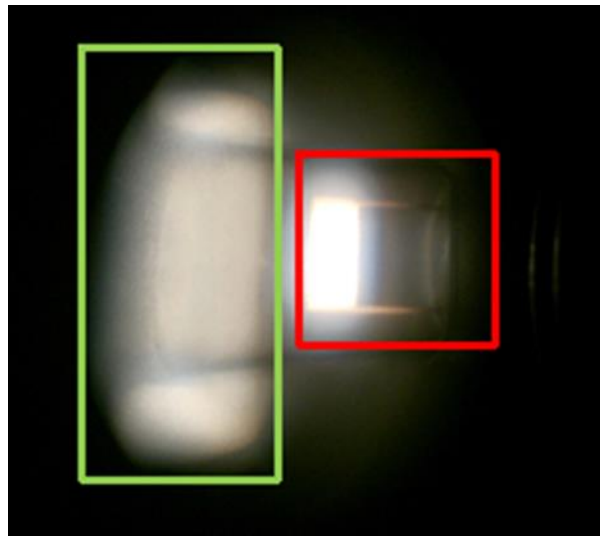

Figure 41: QTH lamp primary image (red box) and secondary reflected image (green box).

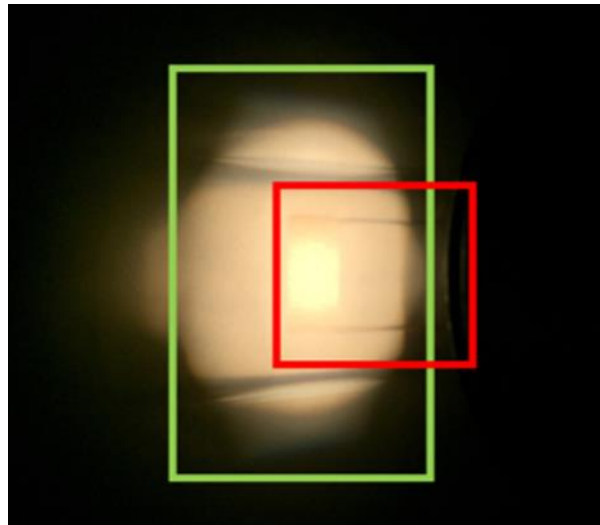

Figure 42: QTH lamp reflected secondary image superimposed onto primary image.

13. Loosen the adjustment lever on the condenser lens assembly shown in Figure 37 so that it can be moved closer to or farther from the lamp housing. The loosened adjustment lever may be pushed or pulled so that it rotates about the cylindrical condenser lens assembly.
14. Move the lever so that it rotates about the cylindrical condenser lens assembly until the light on the backdrop becomes uniform and circular as seen in Figure 43. This is done by defocusing the beam, or moving the adjustment lever to what is usually its farthest position from the lamp housing.
15. Tighten the adjustment knob to lock it into position when the image seen on the backdrop matches Figure 43. If there are any dark spots or inconsistencies in brightness, repeat steps 7 through 13 for QTH lamp alignment.

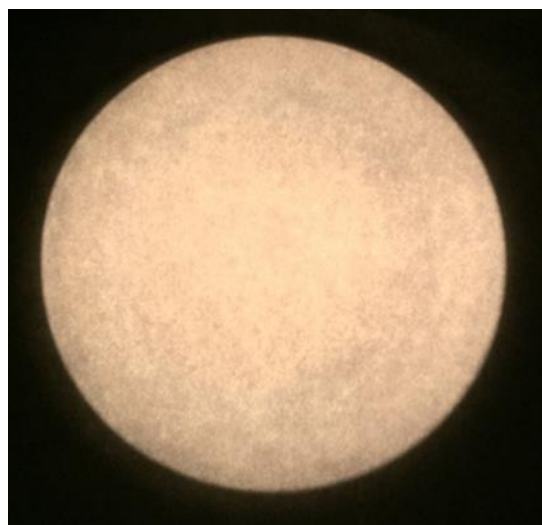

Figure 43: The light output of a properly aligned QTH lamp.

XENON ARC LAMP ALIGNMENT

(See page 42 for QTH Lamp Alignment)

During the lamp alignment process, the lamp must be operated at its rated operating power or current. This is required in order to achieve a light output bright enough to visibly confirm each step of the lamp alignment procedure has been completed correctly. For arc lamps, it is recommended to operate the lamp with the power supply in Constant Power mode for better long term output stability and lamp lifetime. The appropriate settings are noted in the table below.

Model	Power	Current
TLS130B-300X	300 W	15 A

The input and output slits inserted into the fixed slit holders of the monochromator should be 600 μm , in order to allow the most light output from the TLS.

1. Turn on the TLS power supply and verify the settings shown in the table.
2. Connect the monochromator to a computer with TracQ Basic, Oriel Mono Utility or Mono Term software installed. The optional model 74009 hand controller may be used if a computer is not present.
3. Turn on the monochromator. Use the software or hand controller to go to wavelength "0".
4. Ignite the TLS lamp.
5. Position the backdrop a few inches from the output of the TLS. The backdrop must be placed at a distance the full output beam of the TLS can be seen.
6. Loosen the adjustment lever on the condenser lens assembly shown in Figure 37, by turning the knob at the top of the lever counterclockwise, so that it can be moved closer to or farther from the lamp housing. The loosened adjustment lever may be pushed or pulled so that it rotates about the cylindrical condenser lens assembly.
7. Move the lever so that it rotates about the cylindrical condenser lens assembly until the arc between the anode and cathode becomes visible. This is usually achieved when the adjustment lever is as farthest from the lamp housing as possible. A smaller, secondary image may also be visible on the backdrop. This is the reflection of the arc from the rear reflector inside the housing as seen in Figure 44.

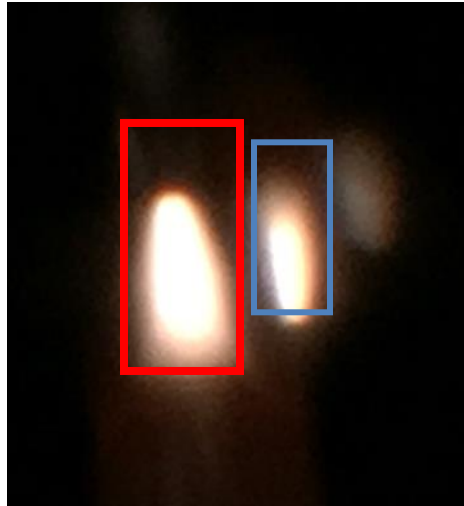

Figure 44: Xe arc lamp primary image (red) and secondary reflected image (blue).

8. Tighten the condenser adjustment knob to lock it into position.
9. Rotate the grey horizontal and vertical lamp position knobs to move the primary image of the lamp until the arc between the anode and cathode is horizontally and vertically centered within the circular output of the TLS as shown in Figure 45.



Figure 45: Xe arc lamp output with primary arc image centered.

10. When the primary arc is centered, lock both lamp position adjustment knobs in place by tightening the silver locking screws behind each grey knob. Rotate the silver locking screws clockwise to tighten.
11. A reflector is located behind the lamp inside the lamp housing. The position of the reflector is adjusted using the knobs located on the side of the lamp housing, as shown in Figure 39. The lamp's reflected image is referred to as the "secondary image". Figure 44 shows the lamp arc's primary image in the

red box and the secondary image in the blue box. Using the reflector adjustment knobs, ensure the secondary image is as sharp as possible. This may require loosening the condenser lens assembly adjustment knob and defocusing the primary image of the lamp anode and cathode, in order to achieve a sharper secondary image of the arc between the anode and cathode. Then overlay or superimpose the reflector's secondary image of the arc onto the primary image of the arc as shown in Figure 46. See Figure 39 for reference on how the secondary image is displaced relative to which knob is adjusted in each direction.

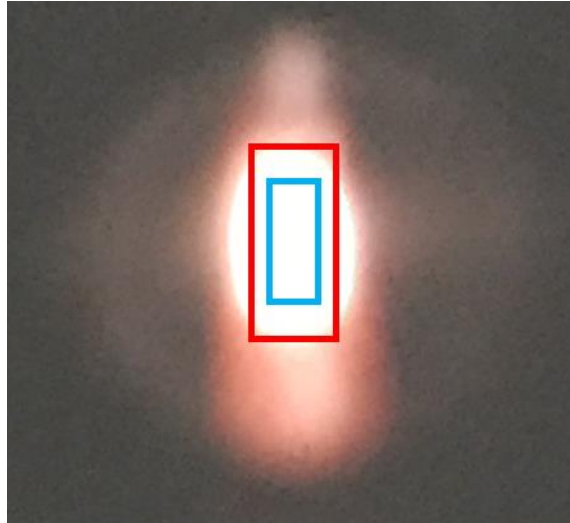

Figure 46: Primary (red) and secondary (blue) Xe arc lamp images superimposed for alignment.

12. Loosen the adjustment lever on the condenser lens assembly shown in Figure 37 so that it can be moved closer to or farther from the lamp housing. The loosened adjustment lever may be pushed or pulled so that it rotates about the cylindrical condenser lens assembly.
13. Move the lever so that it rotates about the cylindrical condenser lens assembly until the light on the backdrop becomes uniform and circular as seen in Figure 47.

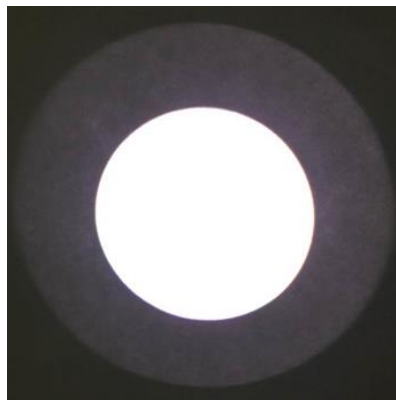

Figure 47: Uniform output of a properly aligned Xe lamp.

MONOCHROMATOR RESOLUTION

The following formula illustrates the effect of monochromator slit widths on the resolution of the instrument. The dispersion is a function of the grating design, and may be different for a customized system.

$$\text{Slit Width (mm)} \times \text{Reciprocal of the Dispersion (nm/mm)} = \text{Resolution at blaze wavelength}$$

Grating	Wavelength Range	Reciprocal Dispersion	Blaze Wavelength	Lines/mm
#1	200 nm to 690 nm	11.0 nm/mm	400 nm	600
#2	690 nm to 2400 nm	10.6 nm/mm	1000 nm	600

Slit Width (mm)	Grating 1 Resolution (nm)	Grating 2 Resolution (nm)
0.05	0.6	0.5
.120	1.3	1.3
.280	3.1	3.0
.600	6.6	6.4
.760	8.4	8.1
1.24	13.6	13.1
1.56	17.2	16.6
3.16	34.8	33.5

OUTPUT OPTICS

MANUAL IRIS

The TLS Systems include a manual iris as shown in Figure 48. Moving the lever varies the output diameter of the TLS, allowing or blocking more light to be output from the system. To increase the output diameter of the TLS and thus the amount of light output, move the lever by hand upward. The iris diaphragm will reach its maximum opening aperture of 36 mm diameter when the lever is completely oriented vertically. To reduce the amount of light output from the TLS, move the lever by hand downward. The iris diaphragm will close to its minimum opening aperture of 2 mm diameter when the lever is completely oriented horizontally. The manual iris provides a convenient fix in the case of detector saturation by allowing a quick method of attenuating the light without requiring a neutral density filter.



Figure 48: Manual iris added to the output optics of the TLS.

OUTPUT FLANGE

The output optics of the TLS has been coupled to an adapter (LT10-UADPT) to allow for coupling to Oriel's standard 1.5 inch flange system. Manually turning this 1.5 inch flange counterclockwise allows for removal of this flange from the TLS system. A 1 inch diameter female flange will now be on the output of the TLS, expanding the mechanical compatibility of the TLS. A 1 inch diameter flange now allows the TLS to be coupled to variety of Newport Corporation products, such as NIST traceable calibrated photodiodes. When the TLS is not in use, it is recommended to replace the red cap (and 1.5 inch flange if necessary) that came fixed to the 1.5 inch flange adapter, in order to prevent dust from entering the lens tube of the unit.

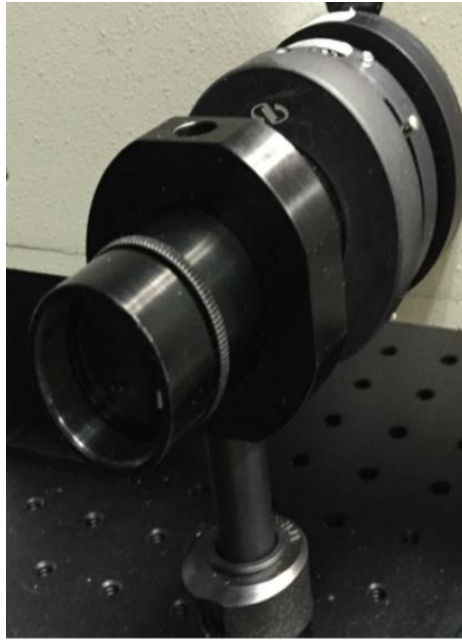

Figure 49: The 1.5 inch flange adapter of the TLS can be removed to reduce the output flange to 1.0 inch, increasing the mechanical compatibility of the TLS

COUPLING ADDITIONAL OPTICS OR A FIBER TO THE TLS

If additional optics or an optical fiber is required to be added to the TLS, Newport offers all necessary mechanical and optical components required.

MOUNTING A LENS/FILTER

Newport Corporation offers additional bandpass filters, neutral density filters, and focusing lenses if the output light of the TLS needs to be additionally altered to meet the specific requirements of a unique application.

Users may find the 77330 Focusing Lens Assembly especially useful for focusing the output of the TLS. By using the lever on the assembly, the user can focus the light output of the TLS at a single point and adjust this focal point over a range of distances from the end of the TLS. Focusing lenses must be purchased separately and installed by the user.



Figure 50: The 77330 Focusing Lens Assembly coupled to the TLS. The bottom view shows the 77792 male-male flange for mechanical coupling.

Lens/Filter Holders	
Part Number	Description
77730	Focusing Lens Assembly, Requires 1.0 in. diameter optics, 1.5 in. female/1.5 in. male flanges
7123	Flange Mounted Cell, 1.0 in. Diameter Optics, 1.5 in. female/1.5 in. male flanges
71306	Quick Connect Flange Mounted Cell, 1.0 in. Diameter Optics, 1.5 in. female/1.5 in. male flanges
6195	Flanged Lens Holder, 1.5 in. Diameter Optics, 1.5 in. female/1.5. inch male flanges
Mechanical Coupling	
Part Number	Description
77790	Quick Connect Flange Converter, 1.5 Inch Flange, Double Female
77791	Quick Connect Coupling Ring, 1.5 Inch Flange, Double Female
77792	Quick Connect Coupling Ring, 1.5 Inch Flange, Double Male

More information about these parts can be found at Newport.com

COUPLING A FIBER

For applications requiring a fiber coupled light source, an optical fiber or optical fiber bundle can be coupled to the end of the Tunable Light Source. Newport offers a variety of fiber options, varying in wavelength transmittance, NA, fiber length, etc.

Fiber/Fiber Bundle Coupling Accessories	
77776	Fiber Bundle Focusing Assembly, FS Aspheric, F/2.2, 800 μ m Spot
77779	Fiber Bundle Focusing Assembly, Glass Aspheric, F/0.85, 4 mm Spot
77800	Fiber Bundle Focusing Assembly, Plano Convex, Fused Silica, F/2, 4 mm Spot
70456	Single SMA Fiber Holder, 1.5 Inch Series Female Flange
77357	Fiber Bundle Mount, Circular Bundle to 1.5 Inch Female Flange
77358	Fiber Bundle Mount, Rectangular Bundle to 1.5 Inch Female Flange
77817	Fiber Bundle Mount, Circular Bundle to 1.5 Inch Male Flange
77802	XYZ Adjust 11 mm Fiber Bundle Holder, 1.5 Inch Male Flange
Ferrule Converters	
77670	Ferrule Converter, SMA Termination to 11mm Standard Ferrule
77675	Ferrule Converter, ST Termination to 11mm Standard Ferrule



Figure 51: Fiber bundle coupled to the output of the TLS with a fiber bundle focusing assembly.

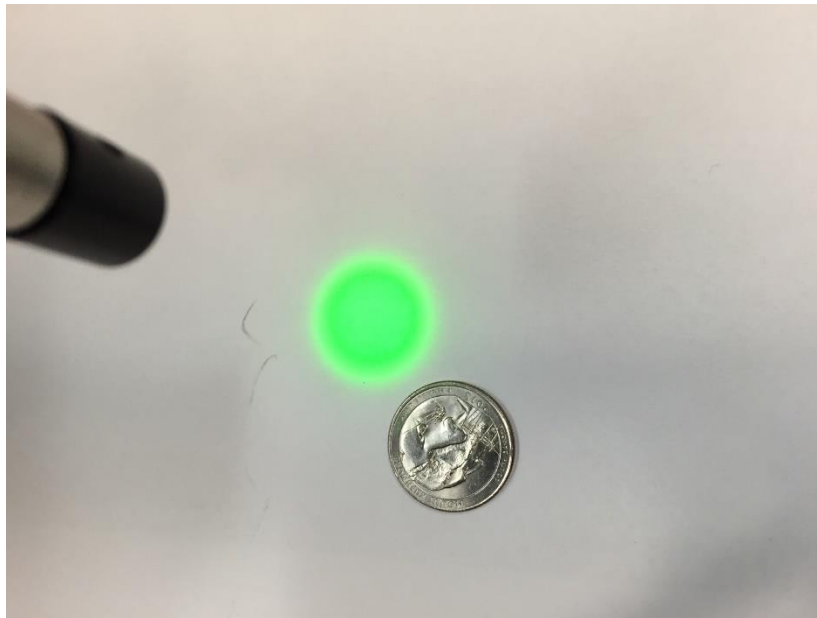

Figure 52: The spot size output of the TLS with the use of a fiber light guide.

MAINTENANCE

LAMP REPLACEMENT

The average life of each lamp type is noted below. Note that the lifetime of the lamp can be affected by the manner in which it is used. Frequent ignitions, contamination of the lamp envelope and an excessively hot operating environment can all lead to reduced lamp life.

To avoid system down time, consider purchasing a replacement lamp as the lamp nears the end of its useful life.

<u>Lamp</u>	<u>Model</u>	<u>Average Lifetime</u>
250W QTH	6334NS	50 hours
300W Xe	6258	900 hours

The hours of lamp use should be regularly monitored on the lamp's power supply, and reset when the lamp is replaced. To check the lamp hours on the power supply, press the horizontal menu button under the icon on the LCD display marked Display. When the corresponding Display menu appears, use the scroll wheel until the red indicator is to the left of Lamp Hours. Then, press the horizontal menu button Display or the button marked CLEAR observe the number of hours the currently installed lamp has been operated.

Always wear powder-free gloves and eye protection when handling a lamp and read all precautions that came with the replacement lamp. The system should be powered off and unplugged. During lamp replacement, it is an ideal time to inspect the lamp housing for signs of wear. Refer to the next section for more information.

When an arc lamp is to be replaced, remove the old lamp and unscrew the brass socket adapter from the bottom terminal. On the replacement lamp, remove the thumbscrew on the bottom terminal and screw on the brass socket adapter. Refer to the Section XENON LAMP INSTALLATION of this manual for more information.

To reset the lamp hours on the power supply, the power supply must be turned on while the lamp is off.

1. Press the horizontal menu button under the Setup indicator on the LCD display until the Reset menu is displayed.
2. Press the vertical menu button to the right of the Lamp Hours icon on the LCD display to reset the lamp hours displayed on the power supply.

CLEANING

Clean the exterior of the system using a clean, dry cloth. Ensure that the ventilation holes are not blocked with dust. Vacuum the openings, if necessary.

When not in use, cover the output port of the Tunable Light Source.

ARC LAMP HOUSING INSPECTION

The material used inside an arc lamp housing is subjected to UV light whenever the lamp is powered. UV light will eventually cause degradation of materials.

When the lamp is being replaced, one can examine the interior of the lamp housing to check for signs of wear. Particular attention should be paid to all wiring and the white high voltage cables. These items are

visible during normal lamp replacement. Never remove the top cover of the lamp housing. The ignitor circuit contains high voltages, even when not powered up.

The rear reflector should not be cleaned. It has a special coating on it to enhance UV throughput, this coating will be damaged if it is wiped. If the reflector became coated with contaminants that were ingested by the lamp housing's fan, it must be replaced.

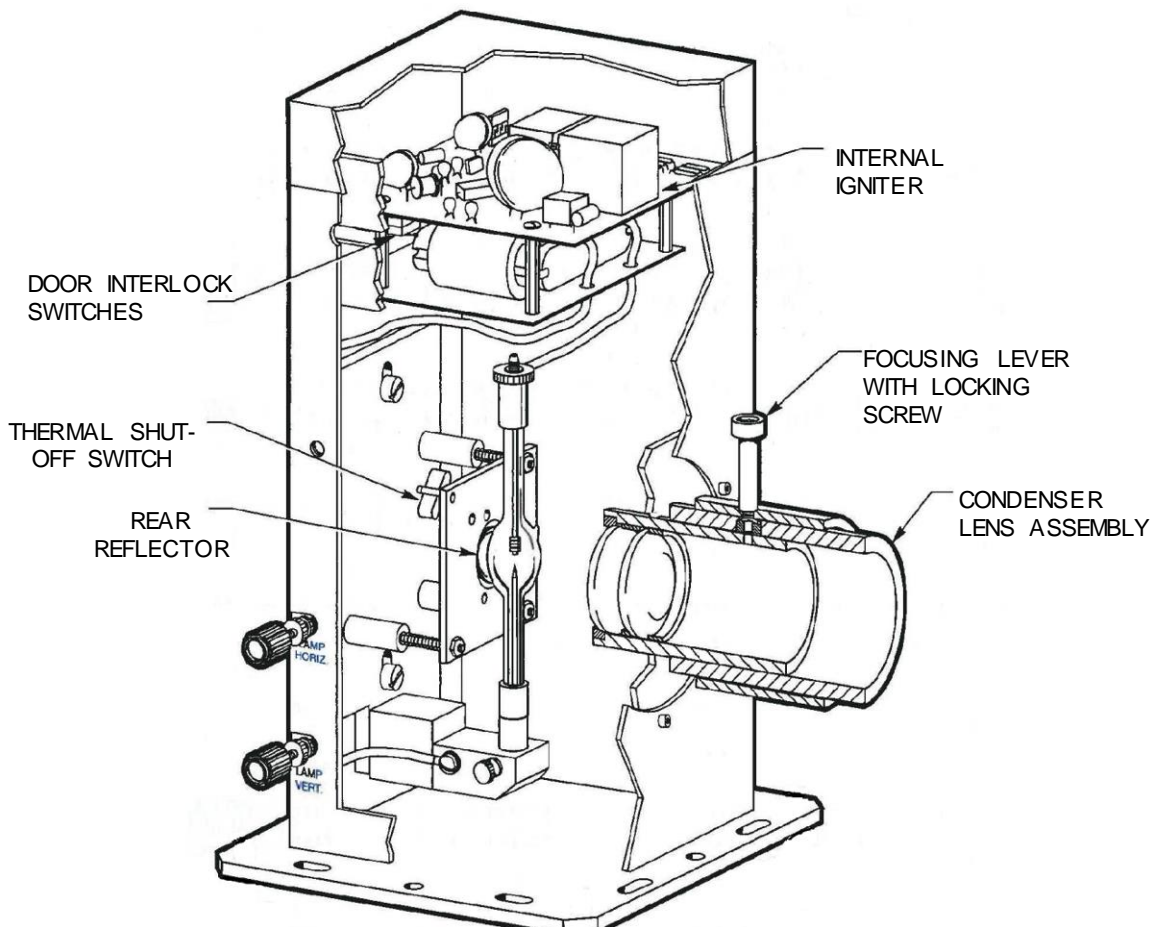

Figure 53: Arc Lamp Housing Construction

If the rear reflector or wiring requires replacement, contact Oriel Instruments or the representative through whom this equipment was purchased for servicing. A Repair Material Authorization (RMA) number is required before sending any item in for servicing.

QTH LAMP HOUSING INSPECTION

The material used inside arc lamp housing is subjected to UV light whenever the lamp is powered. UV light will eventually cause degradation of materials.

When the lamp housing door has been removed to replace the lamp, it is the ideal time to examine the lamp housing for signs of wear.

The rear reflector should not be cleaned. It has a special coating on it to enhance UV throughput, this coating will be damaged if it is wiped. If the reflector became coated with contaminants that were ingested by the lamp housing's fan, it must be replaced.

The socket adapter that the lamp plugs into will eventually become worn. Consider replacing this item periodically. The frequency at which a replacement should be installed will vary depending on the operator, environment and usage.

The field-replaceable QTH lamp socket adapter is model 60043.

Contact Oriel Instruments or the representative through whom this equipment was purchased for servicing. A Repair Material Authorization (RMA) number is required before sending any item in for servicing.

TROUBLESHOOTING

POWER SUPPLY ERROR MESSAGES

The power supply will display an error message to indicate various reasons as to why a lamp cannot be ignited. Only one message can be displayed at one time.

Symptom	Action
Fault light <ul style="list-style-type: none"> • Display shows “Interlock Open” 	Turn off AC power and check <ul style="list-style-type: none"> • Lamp interconnection connection cable(s) are firmly fixed to connectors on power supply and lamp housing • Door to lamp housing is closed. If necessary, loosen the door screws, push the door upward and re-tighten the screws. • If the lamp was running before this error message appeared and the cooling fan of the lamp housing was operational, this indicates too high a temperature inside the lamp housing. Confirm there is no blockage of the cooling fan or vents of the lamp housing.
Fault light <ul style="list-style-type: none"> • Display shows “Ignition Failed” • Ticking sound heard from top of lamp housing during ignition cycle approximately once per second 	This message is displayed usually when trying to ignite and ignition fails. It is a result of no current flow from supply after 5 second of trying to ignite the lamp. <ul style="list-style-type: none"> • Turn off the power supply and disconnect the Lamp Interconnection Cable(s) between the lamp housing and the power supply. • Check lamp connection and polarity inside the lamp housing. A lamp installed upside down or with reversed polarity should be removed and replaced immediately. • Reconnect the Lamp Ignition Cable(s) between the lamp housing and power supply. Turn on the power supply. Re-attempt lamp ignition. • Confirm the hours of usage on the lamp. A lamp approaching the end of its rated lifetime will be difficult to ignite. • Attempt ignition with a new lamp. • If fault repeats contact Newport for RMA information.
Fault light Display shows “Power Supply Failed”	This message is displayed when the power supply cannot be enabled for the lamp or there is a short in the Lamp Housing Interconnection Cable. <ul style="list-style-type: none"> • Turn off the power supply and replace the Lamp Housing Interconnection Cable with one confirmed to be working. • If fault repeats contact Newport for RMA information

If all items are in place, contact Oriol Instruments or the representative from whom this system was purchased for service.

There are no user serviceable parts inside of the power supply. Do not open and attempt to troubleshoot this unit. Contact Oriel Instruments or the representative from whom this system was purchased for service.

DIFFICULTY IGNITING ARC LAMP

If the arc lamp does not ignite, an error message starting “Ignition Failed” will appear on the power supply display. Ignition failure can be due to a number of causes.

The system is designed to operate in a typical laboratory atmosphere. Excessive humidity or condensation on the igniter will cause an “Ignition Failed”. A clicking noise is heard when ignitions are attempted. If the clicking noise is absent, there may be a problem with a component on the igniter itself.

If a replacement lamp is installed upside down, it will likely ignite. However, the lifespan of the lamp is greatly reduced. If the lamp’s electrode has a ball formed on the end, this indicates that the lamp was used incorrectly (shown in Figure 54). This situation is not covered under warranty.

Discoloration of the terminals of the lamp – particularly the top one – can indicate overheating. Normally the fan on the lamp housing begins to operate a few minutes after the lamp is ignited. The fan speed is regulated so that the lamp is maintained at its optimal temperature.

If the lamp envelope is completely black inside, it may indicate that the seal at one of the terminal end caps has broken. This could be due to rough handling, a lamp defect or a failure when overheated.

Some arc lamps are shipped with a wire around its envelope. This is referred to as a “starter wire”, which helps to ignite the lamp. Do not remove this wire.

LAMP CARE AND HANDLING

Do not allow any contaminants or fingerprints to get onto the lamp envelope. Always wear powder-free gloves. If the lamp becomes contaminated, do not use it before cleaning it with isopropyl alcohol. Dry completely before using. If contaminants are not removed, it may lead to reduced light output, overheating, damage to the envelope and premature failure.

LAMP HOUSING THERMOSTAT

The lamp housing is equipped with a shut-off switch, which will activate when the lamp housing becomes too hot. The lamp will be shut off and an “Interlock Open” error message will appear on the power supply display. When the lamp housing temperature returns to normal, the “Interlock Open” error will disappear. The lamp housing will require servicing before the lamp is ignited again. Note that overheating will reduce the lamp’s life.

A NORMAL LAMP A LAMP INSTALLED BACKWARDS

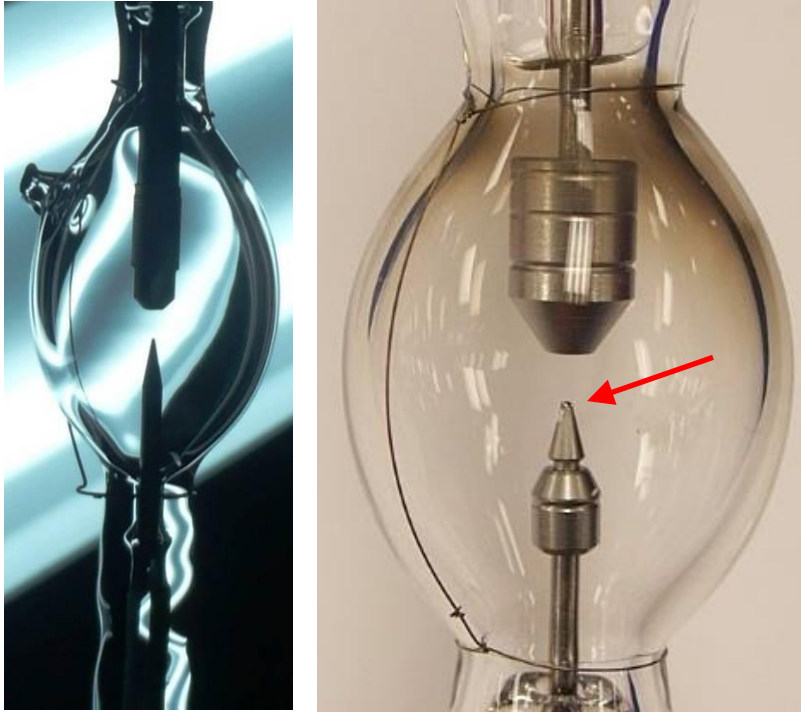

Figure 54: Normal vs. Damaged Arc Lamp

SPECIFICATIONS

TLS SYSTEM

PARAMETER	TLS130B-300X	TLS130B-250Q
Lamp Type	300 W Xenon Arc Lamp	250 W Quartz Tungsten Halogen
Average Lamp Lifetime (hours)	900	50
Lamp Current (A)	13	11
Tunable Range (nm)	300 – 1800	350 - 1800
Certified Range (nm)	300 – 1650	350 - 1650
Computer Interface	USB 2.0 and RS232	
Beam Uniformity ¹	± 15%	
Output Beam Divergence ² (°)	1.75 ± 0.25	2.0 ± 0.25
Beam Diameter ³ (in.) [mm]	0.85 ± 0.05 [21.5 +/- 1.3]	
Light Ripple	< 1%	<0.05%
Wavelength Repeatability ⁴ (nm)	± 0.11	
Wavelength Accuracy ⁵ (nm)	5	
Spectral Resolution ⁶ (nm)	5	
Grating	600 lines/mm ruled diffraction grating, Quantity 2 installed	
Integrated filter wheel	Automated, 6 position motorized	
Filter Wheel Speed	< 2 seconds per position	
Order Sorting Filter	Quantity 4 installed	
Slit	Quantity 2, 280 um (W) x 18 mm (H) Quantity 2, 600 um (W) x 18 mm (H)	
Iris	Manual, 0.08 - 1.42 in. [2 – 36 mm] diameter	
Beam coupling	1" Lens Tube and 1.5" Oriel Female Flange	
Optical Height ⁷ (in.) [mm]	4.6 [116.8]	
Light Intensity Control ⁸	Optional	
TEC Controller Range (°C) ⁸	0 – 25	
Photo Feedback ⁸	Optional	
Shutter Control	Included	
Power Supply Operation Mode	Constant Current, Power, or Intensity ⁸	
AC Voltage Input	Monochromator and OPS Power Supply: 100 to 240 VAC, 47 to 63 Hz	
Operating Temperature (°C)	15 – 40	
Storage Temperature (°C)	0 – 50	
Dimensions (in.) [mm]	30.0 x 18.0 x 15.5 [762 x 457 x 394]	
Weight (lbs.) [kg]	68 [31]	
Software Compatibility	TracQ Basic	

1. Beam uniformity measured with beam profiler at 550nm wavelength.
2. Beam divergence measured in full angle at horizontal axis.
3. Beam diameter measured at 4" from exit aperture.

4. Ability of a wavelength to be consistently reproduced.
5. Capability of the monochromator to output the desired wavelength.
6. Spectral resolution based on 280 μ m slit.
7. Height measured from baseplate.
8. Option light intensity controller purchased is required for this functionality, intensity mode is only operational with this light intensity controller.

SOFTWARE FUNCTION AND REQUIREMENTS

Set General Scan Parameters	Starting and ending wavelength, interval, wait between intervals, prescan wait
Scan Types	Signal vs. wavelength, optical power, external quantum efficiency (AC and DC), transmittance, absorbance, irradiance, time interval, background subtraction
Set Monochromator Parameters	Auto grating and filter change, and open/close shutter
Wavelength Calibration	Adjustment of grating calibration factor and offset parameters
Communication Settings	USB 2.0 and RS232 comm port
Operating System	Microsoft Windows 7 or 10 (32 bit or 64bit)
Processor	2 GHz
RAM	1 GB
Hard Drive	800MB free space

OPTICAL ACCESSORIES AND RELATED PRODUCTS

Newport Power Meters	1918-R 1936-R 2936-R
Lock-In Digital Amplifier	LIDA-SRS-KIT
Focusing Lens Assembly	77330 Requires 1 inch (25.4 mm) diameter lens
Fiber Bundle Focusing Assemblies	77776
Fiber Optics Bundle (Fused Silica)	77563 77564
Coupling Ring, Double Female (Set Screw)	77829
Coupling Ring, Double Female (Quick Connect)	77791
Hand Controller, Cornerstone Monochromator	74009

APPENDIX A: OPTIONAL HAND CONTROLLER

If it is desired to operate the Tunable Light Source without requiring a computer, the model 74009 Cornerstone Hand Controller may be purchased. It can be used to perform all the same basic functions as the software.

Note: when selecting a wavelength, the grating and filter must also be selected via the hand controller. Automatic changeover tables are available only through software.



Figure 55: 74009 Monochromator Hand Controller

WARRANTY AND SERVICE

CONTACTING ORIEL INSTRUMENTS

Oriel Instruments belongs to Newport Corporation's family of brands. Thanks to a steadfast commitment to quality, innovation, hard work and customer care, Newport is trusted the world over as the complete source for all photonics and laser technology and equipment.

Founded in 1969, Newport is a pioneering single-source solutions provider of laser and photonics components to the leaders in scientific research, life and health sciences, photovoltaics, microelectronics, industrial manufacturing and homeland security markets.

Newport Corporation proudly serves customers across Canada, Europe, Asia and the United States through 9 international subsidiaries and 24 sales offices worldwide. Every year, the Newport Resource catalog is hailed as the premier sourcebook for those in need of advanced technology products and services. It is available by mail request or through Newport's website. The website is where one will find product updates, interactive demonstrations, specification charts and more.

To obtain information regarding sales, technical support or factory service, United States and Canadian customers should contact Newport Corporation directly.

Newport Corporation
1791 Deere Avenue
Irvine CA 92606 USA

Telephone: 800-222-6440 (toll-free in United States)
949-253-1727

Fax: 949-253-1680

Sales: oriel.sales@newport.com
Technical assistance: oriel.tech@newport.com
Repair Service: rma.service@newport.com

Customers outside of the United States must contact their regional representative for all sales, technical support, and service inquiries. A list of worldwide representatives can be found on Newport's website: <https://www.newport.com/contact/contactslocations>.

REQUEST FOR ASSISTANCE / SERVICE

Please have the following information available when requesting assistance or service:

- Contact information for the owner of the product.
- Instrument model number (located on the product label).
- Product serial number and date of manufacture (located on the product label).
- Description of the problem.

To help Oriel's Technical Support Representatives diagnose the problem, please note the following:

- Is the system used for manufacturing or research and development?
- What was the state of the system right before the problem?
- Had this problem occurred before? If so, when and how frequently?
- Can the system continue to operate with this problem, or is it non-operational?
- Were there any differences in the application or environment before the problem occurred?

REPAIR SERVICE

This section contains information regarding factory service for this product. The user should not attempt any maintenance or service of the system beyond the procedures outlined in this manual. This product contains no user serviceable parts other than what is noted in this manual. Any problem that cannot be resolved should be referred to Oriel Instruments.

If the instrument needs to be returned for service, a Return Material Authorization (RMA) number must be obtained prior to shipment to Newport Corporation. This RMA number must appear on both the shipping container and the package documents.

Return the product to Newport Corporation, freight prepaid, clearly marked with the RMA number and it either will be repaired or replaced at Newport's discretion.

Newport is not responsible for damage occurring in transit. The Owner of the product bears all risk of loss or damage to the returned Products until delivery at Newport's facility. Newport is not responsible for product damage once it has left the facility after repair or replacement has been completed.

Newport is not obligated to accept products returned without an RMA number. Any return shipment received by Newport without an RMA number may be reshipped by Newport, freight collect, to the Owner of the product.

NON-WARRANTY REPAIR

For Products returned for repair that are not covered under warranty, Newport's standard repair charges shall be applicable in addition to all shipping expenses. Unless otherwise stated in Newport's repair quote, any such out-of-warranty repairs are warranted for ninety (90) days from date of shipment of the repaired Product.

Newport will charge an evaluation fee to examine the product and determine the most appropriate course of action. Payment information must be obtained prior to having an RMA number assigned. Customers may use a valid credit card, and those who have an existing account with Newport Corporation may use a purchase order.

When the evaluation had been completed, the owner of the product will be contacted and notified of the final cost to repair or replace the item. If the decision is made to not proceed with the repair, only the evaluation fee will be billed. If authorization to perform the repair or provide a replacement is obtained, the evaluation fee will be applied to the final cost. A revised purchase order must be submitted for the final cost. If paying by credit card, written authorization must be provided that will allow the full repair cost to be charged to the card.

WARRANTY REPAIR

If there are any defects in material or workmanship or a failure to meet specifications, notify Newport promptly, prior to the expiration of the warranty.

Except as otherwise expressly stated in Newport's quote or in the current operating manual or other written guarantee for any of the Products, Newport warrants that, for the period of time set forth below with respect to each Product or component type (the "Warranty Period"), the Products sold hereunder will be free from defects in material and workmanship, and will conform to the applicable specifications, under normal use and service when correctly installed and maintained. Newport shall repair or replace, at Newport's sole option, any defective or nonconforming Product or part thereof which is returned at Buyer's expense to Newport facility, provided, that Buyer notifies Newport in writing promptly after discovery of the defect or nonconformity and within the Warranty Period. Products may only be returned by Buyer when accompanied by a return material authorization number ("RMA number") issued by Newport, with freight prepaid by Buyer. Newport shall not be responsible for any damage occurring in transit or obligated to accept Products returned for warranty repair without an RMA number. Buyer bears all risk of loss or damage to the Products until delivery at Newport's facility. Newport shall pay for shipment back to Buyer for Products repaired under warranty.

WARRANTY PERIOD

All Products (except consumables such as lamps, filters, etc.) described here are warranted for a period of twelve (12) months from the date of shipment or 3000 hours of operation, whichever comes first.

Lamps, gratings, optical filters and other consumables / spare parts (whether sold as separate Products or constituting components of other Products) are warranted for a period of ninety (90) days from the date of shipment.

WARRANTY EXCLUSIONS

The above warranty does not apply to Products which are (a) repaired, modified or altered by any party other than Newport; (b) used in conjunction with equipment not provided or authorized by Newport; (c) subjected to unusual physical, thermal, or electrical stress, improper installation, misuse, abuse, accident or negligence in use, storage, transportation or handling, alteration, or tampering, or (d) considered a consumable item or an item requiring repair or replacement due to normal wear and tear.

DISCLAIMER OF WARRANTIES: EXCLUSIVE REMEDY

THE FOREGOING WARRANTY IS EXCLUSIVE AND IN LIEU OF ALL OTHER WARRANTIES. EXCEPT AS EXPRESSLY PROVIDED HEREIN, NEWPORT MAKES NO WARRANTIES, EITHER EXPRESS OR IMPLIED, EITHER IN FACT OR BY OPERATION OF LAW, STATUTORY OR OTHERWISE, REGARDING THE PRODUCTS, SOFTWARE OR SERVICES. NEWPORT EXPRESSLY DISCLAIMS ANY IMPLIED WARRANTIES OF MERCHANTABILITY OR FITNESS FOR A PARTICULAR PURPOSE FOR THE PRODUCTS, SOFTWARE OR SERVICES. THE OBLIGATIONS OF NEWPORT SET FORTH IN THIS SECTION SHALL BE NEWPORT'S SOLE LIABILITY, AND BUYER'S SOLE REMEDY, FOR BREACH OF THE FOREGOING WARRANTY. Representations and warranties made by any person including distributors, dealers, and representatives of Oriel / Newport Corporation which are inconsistent or in conflict with the terms of this warranty shall not be binding on Newport unless reduced to writing and approved by an expressly an authorized officer of Newport.

LOANER / DEMO MATERIAL

Persons receiving goods for demonstrations or temporary use or in any manner in which title is not transferred from Newport shall assume full responsibility for any and all damage while in their care, custody and control. If damage occurs, unrelated to the proper and warranted use and performance of the goods, recipient of the goods accepts full responsibility for restoring the goods to their original condition upon delivery, and for assuming all costs and charges.

Confidentiality & Proprietary Rights

Reservation of Title:

The Newport programs and all materials furnished or produced in connection with them ("Related Materials") contain trade secrets of Newport and are for use only in the manner expressly permitted. Newport claims and reserves all rights and benefits afforded under law in the Programs provided by Newport Corporation. Newport shall retain full ownership of Intellectual Property Rights in and to all development, process, align or assembly technologies developed and other derivative work that may be developed by Newport. Customer shall not challenge, or cause any third party to challenge the rights of Newport.

Preservation of Secrecy and Confidentiality and Restrictions to Access:

Customer shall protect the Newport Programs and Related Materials as trade secrets of Newport, and shall devote its best efforts to ensure that all its personnel protect the Newport Programs as trade secrets of Newport Corporation. Customer shall not at any time disclose Newport's trade secrets to any other person, firm, organization, or employee that does not need (consistent with Customer's right of use hereunder) to obtain access to the Newport Programs and Related Materials. These restrictions shall not apply to information (1) generally known to the public or obtainable from public sources; (2) readily apparent from the keyboard operations, visual display, or output reports of the Programs; (3) previously in the possession of Customer or subsequently developed or acquired without reliance on the Newport Programs; or (4) approved by Newport for release without restriction.

First printing 2015

© 2015 by Newport Corporation, Irvine, CA. All rights reserved.
No part of this manual may be reproduced or copied without the prior written approval of Newport Corporation.

This manual has been provided for information only and product specifications are subject to change without notice.
Any change will be reflected in future printings.

Newport Corporation 1791 Deere Avenue Irvine, CA, 92606 USA